

GENUS BOUNDS FOR MINIMAL SURFACES ARISING FROM MIN-MAX CONSTRUCTIONS

CAMILLO DE LELLIS AND FILIPPO PELLANDINI

ABSTRACT. In this paper we prove genus bounds for closed embedded minimal surfaces in a closed 3-dimensional manifold constructed via min-max arguments. A stronger estimate was announced by Pitts and Rubinstein but to our knowledge its proof has never been published. Our proof follows ideas of Simon and uses an extension of a famous result of Meeks, Simon and Yau on the convergence of minimizing sequences of isotopic surfaces. This result is proved in the second part of the paper.

CONTENTS

0. Introduction	1
1. Preliminaries and statement of the result	6
2. Overview of the proof	9
3. Proof of Proposition 2.1. Part I: Minimizing sequences of isotopic surfaces	13
4. Proof of Proposition 2.1. Part II: Leaves	14
5. Proof of Proposition 3.2. Part I: Convex hull property	20
6. Proof of Proposition 3.2. Part II: Squeezing Lemma	25
7. Proof of Proposition 3.2. Part III: γ -reduction	28
8. Proof of Proposition 3.2. Part IV: Boundary regularity.	31
9. Proof of Proposition 3.2. Part V: Convergence of connected components	40
10. Considerations on (0.5) and (0.4)	41
Appendix A. Proof of Lemma 4.2	42
Appendix B. Proof of Lemma 5.5	44
Appendix C. A simple topological fact	44
References	45

0. INTRODUCTION

0.1. **Min-max surfaces.** In [8] Tobias H. Colding and the second author started a survey on constructing closed embedded minimal surfaces in a closed 3-dimensional manifold via min-max arguments, including results of F. Smith, L. Simon, J. Pitts and H. Rubinstein. This paper completes the survey by giving genus bounds for the final minmax surface.

The basic idea of min-max arguments over sweep-outs goes back to Birkhoff, who used such a method to find simple closed geodesics on spheres. In particular when M^2 is the 2-dimensional sphere we can find a 1-parameter family of curves starting and ending at a point curve in such a way that the induced map $F : \mathbf{S}^2 \rightarrow \mathbf{S}^2$ has nonzero degree. Birkhoff's argument (or the min-max argument) allows us to conclude that M has a nontrivial closed

geodesic of length less than or equal to the length of the longest curve in the 1-parameter family. A curve shortening argument gives that the geodesic obtained in this way is simple.

Following [8] we introduce a suitable generalized setting for sweepouts of 3-manifolds by two-dimensional surfaces. From now on, M , Diff_0 and $\mathfrak{I}\mathfrak{s}$ will denote, respectively, a closed 3-dimensional Riemannian manifold, the identity component of the diffeomorphism group of M , and the set of smooth isotopies. Thus $\mathfrak{I}\mathfrak{s}$ consists of those maps $\psi \in C^\infty([0, 1] \times M, M)$ such that $\psi(0, \cdot)$ is the identity and $\psi(t, \cdot) \in \text{Diff}_0$ for every t .

Definition 0.1. *A family $\{\Sigma_t\}_{t \in [0,1]}$ of surfaces of M is said to be continuous if*

- (c1) $\mathcal{H}^2(\Sigma_t)$ is a continuous function of t ;
- (c2) $\Sigma_t \rightarrow \Sigma_{t_0}$ in the Hausdorff topology whenever $t \rightarrow t_0$.

A family $\{\Sigma_t\}_{t \in [0,1]}$ of subsets of M is said to be a generalized family of surfaces if there are a finite subset T of $[0, 1]$ and a finite set of points P in M such that

- 1. (c1) and (c2) hold;
- 2. Σ_t is a surface for every $t \notin T$;
- 3. For $t \in T$, Σ_t is a surface in $M \setminus P$.

With a small abuse of notation, we shall use the word ‘‘surface’’ even for the sets Σ_t with $t \in T$. To avoid confusion, families of surfaces will always be denoted by $\{\Sigma_t\}$. Thus, when referring to a surface a subscript will denote a real parameter, whereas a superscript will denote an integer as in a sequence.

Given a generalized family $\{\Sigma_t\}$ we can generate new generalized families via the following procedure. Take an arbitrary map $\psi \in C^\infty([0, 1] \times M, M)$ such that $\psi(t, \cdot) \in \text{Diff}_0$ for each t and define $\{\Sigma'_t\}$ by $\Sigma'_t = \psi(t, \Sigma_t)$. We will say that a set Λ of generalized families is *saturated* if it is closed under this operation.

Remark 0.2. *For technical reasons we require an additional property for any saturated set Λ considered in this paper: the existence of some $N = N(\Lambda) < \infty$ such that for any $\{\Sigma_t\} \subset \Lambda$, the set P in Definition 0.1 consists of at most N points.*

Given a family $\{\Sigma_t\} \in \Lambda$ we denote by $\mathcal{F}(\{\Sigma_t\})$ the area of its maximal slice and by $m_0(\Lambda)$ the infimum of \mathcal{F} taken over all families of Λ ; that is,

$$\mathcal{F}(\{\Sigma_t\}) = \max_{t \in [0,1]} \mathcal{H}^2(\Sigma_t) \quad \text{and} \quad (0.1)$$

$$m_0(\Lambda) = \inf_{\Lambda} \mathcal{F} = \inf_{\{\Sigma_t\} \in \Lambda} \left[\max_{t \in [0,1]} \mathcal{H}^2(\Sigma_t) \right]. \quad (0.2)$$

If $\lim_n \mathcal{F}(\{\Sigma_t\}^n) = m_0(\Lambda)$, then we say that the sequence of generalized families of surfaces $\{\{\Sigma_t\}^n\} \subset \Lambda$ is a *minimizing sequence*. Assume $\{\{\Sigma_t\}^n\}$ is a minimizing sequence and let $\{t_n\}$ be a sequence of parameters. If the areas of the slices $\{\Sigma_{t_n}^n\}$ converge to m_0 , i.e. if $\mathcal{H}^2(\Sigma_{t_n}^n) \rightarrow m_0(\Lambda)$, then we say that $\{\Sigma_{t_n}^n\}$ is a *min-max sequence*.

An important point in the min-max construction is to find a saturated Λ with $m_0(\Lambda) > 0$. For instance, this can be done by using the following elementary proposition proven in the Appendix of [8].

Proposition 0.3. *Let M be a closed 3-manifold with a Riemannian metric and let $\{\Sigma_t\}$ be the level sets of a Morse function. The smallest saturated set Λ containing the family $\{\Sigma_t\}$ has $m_0(\Lambda) > 0$.*

The paper [8] reports a proof of the following regularity result.

Theorem 0.4. *[Simon–Smith] Let M be a closed 3-manifold with a Riemannian metric. For any saturated Λ , there is a min–max sequence $\Sigma_{t_n}^n$ converging in the sense of varifolds to a smooth embedded minimal surface Σ with area $m_0(\Lambda)$ (multiplicity is allowed).*

0.2. Genus bounds. In this note we bound the topology of Σ under the assumption that the t –dependence of $\{\Sigma_t\}$ is smoother than just the continuity required in Definition 0.1. This is the content of the next definition.

Definition 0.5. *A generalized family $\{\Sigma_t\}$ as in Definition 0.1 is said to be smooth if:*

- (s1) Σ_t varies smoothly in t on $[0, 1] \setminus T$;
- (s2) For $t \in T$, $\Sigma_\tau \rightarrow \Sigma_t$ smoothly in $M \setminus P$.

Here P and T are the sets of requirements 2. and 3. of Definition 0.1. We assume further that Σ_t is orientable for any $t \notin T$.

Note that, if a set Λ consists of smooth generalized families, then the elements of its saturation are still smooth generalized families. Therefore the saturated set considered in Proposition 0.3 is smooth.

We next introduce some notation which will be consistently used during the proofs. We decompose the surface Σ of Theorem 0.4 as $\sum_{i=1}^N n_i \Gamma^i$, where the Γ^i 's are the connected components of Σ , counted without multiplicity, and $n_i \in \mathbb{N} \setminus \{0\}$ for every i . We further divide the components $\{\Gamma^i\}$ into two sets: the orientable ones, denoted by \mathcal{O} , and the non–orientable ones, denoted by \mathcal{N} . We are now ready to state the main theorem of this paper.

Theorem 0.6. *Let Λ be a saturated set of smooth generalized families and Σ and $\Sigma_{t_n}^n$ the surfaces produced in the proof of Theorem 0.4 given in [8]. Then*

$$\sum_{\Gamma^i \in \mathcal{O}} \mathbf{g}(\Gamma^i) + \frac{1}{2} \sum_{\Gamma^i \in \mathcal{N}} (\mathbf{g}(\Gamma^i) - 1) \leq \mathbf{g}_0 := \liminf_{j \uparrow \infty} \liminf_{\tau \rightarrow t_j} \mathbf{g}(\Sigma_\tau^j). \quad (0.3)$$

Remark 0.7. *According to our definition, $\Sigma_{t_j}^j$ is not necessarily a smooth submanifold, as t_j could be one of the exceptional parameters of point 3. in Definition 0.1. However, for each fixed j there is an $\eta > 0$ such that Σ_t^j is a smooth submanifold for every $t \in]t_j - \eta, t_j[\cup]t_j, t_j + \eta[$. Hence the right hand side of (0.3) makes sense.*

In fact the inequality (0.3) holds with $\mathbf{g}_0 = \liminf_j \mathbf{g}(\Sigma^j)$ for every limit Σ of a sequence of surfaces Σ^j 's that enjoy certain requirements of variational nature, i.e. that are *almost minimizing in sufficiently small annuli*. The precise statement will be given in Theorem 1.6, after introducing the suitable concepts.

As usual, when Γ is an orientable 2–dimensional connected surface, its genus $\mathbf{g}(\Gamma)$ is defined as the number of handles that one has to attach to a sphere in order to get a surface homeomorphic to Γ . When Γ is non–orientable and connected, $\mathbf{g}(\Gamma)$ is defined as the number of cross caps that one has to attach to a sphere in order to get a surface homeomorphic to Γ (therefore, if χ is the Euler characteristic of the surface, then

$$\mathbf{g}(\Gamma) = \begin{cases} \frac{1}{2}(2 - \chi) & \text{if } \Gamma \in \mathcal{N} \\ 2 - \chi & \text{if } \Gamma \in \mathcal{O} \end{cases}$$

see [12]). For surfaces with more than one connected component, the genus is simply the sum of the genus of each connected component.

Our genus estimate (0.3) is weaker than the one announced by Pitts and Rubinstein in [15], which reads as follows (cp. with Theorem 1 and Theorem 2 in [15]):

$$\sum_{\Gamma^i \in \mathcal{O}} n_i \mathbf{g}(\Gamma^i) + \frac{1}{2} \sum_{\Gamma^i \in \mathcal{N}} n_i \mathbf{g}(\Gamma^i) \leq \mathbf{g}_0. \quad (0.4)$$

In Section 10 a very elementary example shows that (0.4) is false for sequences of almost minimizing surfaces (in fact even for sequences which are locally strictly minimizing). In this case the correct estimate should be

$$\sum_{\Gamma^i \in \mathcal{O}} n_i \mathbf{g}(\Gamma^i) + \frac{1}{2} \sum_{\Gamma^i \in \mathcal{N}} n_i (\mathbf{g}(\Gamma^i) - 1) \leq \mathbf{g}_0. \quad (0.5)$$

Therefore, the improved estimate (0.4) can be proved only by exploiting an argument of more global nature, using a more detailed analysis of the min–max construction.

The estimate (0.5) respects the rough intuition that the approximating surfaces Σ^j are, after appropriate surgeries, isotopic to coverings of the surfaces Γ^i . For instance Γ can consist of a single component that is a real projective space, and Σ^j might be the boundary of a tubular neighborhood of Γ of size $\varepsilon_j \downarrow 0$, i.e. a sphere. In this case Σ^j is a double cover of Γ .

Our proof uses the ideas of an unpublished argument of Simon, reported by Smith in [19] to show the existence of an embedded minimal 2–sphere when M is a 3–sphere. These ideas do not seem enough to show (0.4): its proof probably requires a much more careful analysis. In Section 10 we discuss this issue.

Remark 0.8. *The unpublished argument of Simon has been used also by Grüter and Jost in [10]. The core of Simon’s argument is reported here with a technical simplification. We then give a detailed proof of an auxiliary proposition which plays a fundamental role in the argument. This part is, to our knowledge, new: neither Smith, nor Grüter and Jost provide a proof of it. Smith suggests that the proposition can be proved by suitably modifying the arguments of [13] and [4]. Though this is indeed the case, the strategy suggested by Smith leads to a difficulty which we overcome with a different approach: see the discussion in Section 7. Moreover, [19] does not discuss the “convex–hull property” of Section 5, which is a basic prerequisite to apply the boundary regularity theory of Allard in [3] (in fact we do not know of any boundary regularity result in the minimal surface theory which does not pass through some kind of convex hull property).*

0.3. An example. We end this introduction with a brief discussion of how a sequence of closed surface Σ^j could converge, in the sense of varifolds, to a smooth surface with higher genus. This example is a model situation which must be ruled out by any proof of a genus bound. First take a sphere in \mathbf{R}^3 and squeeze it in one direction towards a double copy of a disk (recall that the convergence in the sense of varifolds does not take into account the orientation). Next take the disk and wrap it to form a torus in the standard way. With a standard diagonal argument we find a sequence of smooth embedded spheres in \mathbf{R}^3 which, in the sense of varifolds, converges to a double copy of an embedded torus. See Figure 1 below.

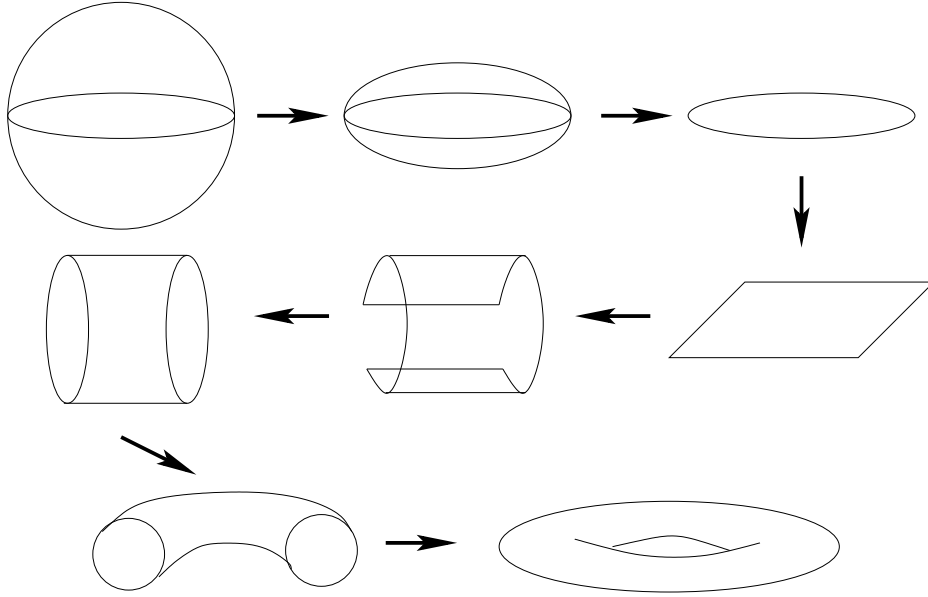

FIGURE 1. Failure of genus bounds under varifold convergence. A sequence of embedded spheres converges to a double copy of a torus.

This example does not occur in min–max sequences for variational reasons. In particular, it follows from the arguments of this paper that such a sequence does not have the almost minimizing property in (sufficiently small) annuli discussed in Section 1.

0.4. Plan of the paper. Section 1 contains: some preliminaries on notational conventions, a summary of the material of [8] used in this note and the most precise statement of the genus bounds (Theorem 1.6). Section 2 gives an overview of the proof of Theorem 1.6. In particular it reduces it to a statement on lifting of paths, which we call Simon’s Lifting Lemma (see Proposition 2.1). Sections 3 and 4 contain a proof of Simon’s Lifting Lemma. In Section 3 we state a suitable modification of a celebrated result of Meeks, Simon and Yau (see [13]) in which we handle minimizing sequences of isotopic surfaces with boundaries (see Proposition 3.2).

Sections 5, 6, 7, 8 and 9 show how to modify the theory of [13] and [4] in order to prove Proposition 3.2. Section 5 discusses the convex–hull properties needed for the boundary regularity. In Section 6 we introduce and prove the “squeezing lemmas” which allow to pass from almost–minimizing sequences to minimizing sequences. Section 7 discusses the γ –reduction and how one applies it to get the interior regularity. We also point out why the γ –reduction cannot be applied directly to the surfaces of Proposition 3.2. Section 8 proves the boundary regularity. Finally, section 9 handles the part of Proposition 3.2 involving limits of connected components.

Section 10 discusses the subtleties of the stronger estimates (0.4) and (0.5).

1. PRELIMINARIES AND STATEMENT OF THE RESULT

1.1. **Notation.** Throughout this paper our notation will be consistent with the one of [8], explained in Section 2 of that paper. For the reader's convenience we recall some of these conventions in the following table.

$T_x M$	the tangent space of M at x
TM	the tangent bundle of M .
$\text{Inj}(M)$	the injectivity radius of M .
\mathcal{H}^2	the 2-d Hausdorff measure in the metric space (M, d) .
\mathcal{H}_e^2	the 2-d Hausdorff measure in the euclidean space \mathbf{R}^3 .
$B_\rho(x)$	open ball
$\overline{B}_\rho(x)$	closed ball
$\partial B_\rho(x)$	distance sphere of radius ρ in M .
$\text{diam}(G)$	diameter of a subset $G \subset M$.
$d(G_1, G_2)$	the Hausdorff distance between the subsets G_1 and G_2 of M .
$\mathcal{D}, \mathcal{D}_\rho$	the unit disk and the disk of radius ρ in \mathbf{R}^2 .
$\mathcal{B}, \mathcal{B}_\rho$	the unit ball and the ball of radius ρ in \mathbf{R}^3 .
\exp_x	the exponential map in M at $x \in M$.
$\mathfrak{Is}(U)$	smooth isotopies which leave $M \setminus U$ fixed.
$G^2(U), G(U)$	grassmannian of (unoriented) 2-planes on $U \subset M$.
$\text{An}(x, \tau, t)$	the open annulus $B_t(x) \setminus \overline{B}_\tau(x)$.
$\mathcal{AN}_r(x)$	the set $\{\text{An}(x, \tau, t) \text{ where } 0 < \tau < t < r\}$.
$C^\infty(X, Y)$	smooth maps from X to Y .
$C_c^\infty(X, Y)$	smooth maps with compact support from X to the vector space Y .

1.2. **Varifolds.** We will need to recall some basic facts from the theory of varifolds; see for instance chapter 4 and chapter 8 of [18] for further information. Varifolds are a convenient way of generalizing surfaces to a category that has good compactness properties. An advantage of varifolds, over other generalizations (like currents), is that they do not allow for cancellation of mass. This last property is fundamental for the min-max construction.

If U is an open subset of M , any finite nonnegative measure on the Grassmannian of unoriented 2-planes on U is said to be a *2-varifold in U* . The Grassmannian of 2-planes will be denoted by $G^2(U)$ and the vector space of 2-varifolds is denoted by $\mathcal{V}^2(U)$. Throughout we will consider only 2-varifolds; thus we drop the 2.

We endow $\mathcal{V}(U)$ with the topology of the weak convergence in the sense of measures, thus we say that a sequence V^k of varifolds converge to a varifold V if for every function $\varphi \in C_c(G(U))$

$$\lim_{k \rightarrow \infty} \int \varphi(x, \pi) dV^k(x, \pi) = \int \varphi(x, \pi) dV(x, \pi).$$

Here π denotes a 2-plane of $T_x M$. If $U' \subset U$ and $V \in \mathcal{V}(U)$, then we denote by $V \llcorner U'$ the restriction of the measure V to $G(U')$. Moreover, $\|V\|$ will be the unique measure on U satisfying

$$\int_U \varphi(x) d\|V\|(x) = \int_{G(U)} \varphi(x) dV(x, \pi) \quad \forall \varphi \in C_c(U).$$

The support of $\|V\|$, denoted by $\text{supp}(\|V\|)$, is the smallest closed set outside which $\|V\|$ vanishes identically. The number $\|V\|(U)$ will be called the *mass of V in U* . When U is clear from the context, we say briefly the *mass of V* .

Recall also that a 2-dimensional rectifiable set is a countable union of closed subsets of C^1 surfaces (modulo sets of \mathcal{H}^2 -measure 0). Thus, if $R \subset U$ is a 2-dimensional rectifiable set and $h : R \rightarrow \mathbf{R}^+$ is a Borel function, then we can define a varifold V by

$$\int_{G(U)} \varphi(x, \pi) dV(x, \pi) = \int_R h(x) \varphi(x, T_x R) d\mathcal{H}^2(x) \quad \forall \varphi \in C_c(G(U)). \quad (1.1)$$

Here $T_x R$ denotes the tangent plane to R in x . If h is integer-valued, then we say that V is an *integer rectifiable varifold*. If $\Sigma = \bigcup n_i \Sigma_i$, then by slight abuse of notation we use Σ for the varifold induced by Σ via (1.1).

1.3. Pushforward, first variation, monotonicity formula. If V is a varifold induced by a surface $\Sigma \subset U$ and $\psi : U \rightarrow U'$ a diffeomorphism, then we let $\psi_{\#} V \in \mathcal{V}(U')$ be the varifold induced by the surface $\psi(\Sigma)$. The definition of $\psi_{\#} V$ can be naturally extended to *any* $V \in \mathcal{V}(U)$ by

$$\int \varphi(y, \sigma) d(\psi_{\#} V)(y, \sigma) = \int J\psi(x, \pi) \varphi(\psi(x), d\psi_x(\pi)) dV(x, \pi);$$

where $J\psi(x, \pi)$ denotes the Jacobian determinant (i.e. the area element) of the differential $d\psi_x$ restricted to the plane π ; cf. equation (39.1) of [18].

Given a smooth vector field χ , let ψ be the isotopy generated by χ , i.e. with $\frac{\partial \psi}{\partial t} = \chi(\psi)$. The first variation of V with respect to χ is defined as

$$[\delta V](\chi) = \left. \frac{d}{dt} (\|\psi(t, \cdot)_{\#} V\|) \right|_{t=0};$$

cf. sections 16 and 39 of [18]. When Σ is a smooth surface we recover the classical definition of first variation of a surface:

$$[\delta \Sigma](\chi) = \int_{\Sigma} \text{div}_{\Sigma} \chi d\mathcal{H}^2 = \left. \frac{d}{dt} (\mathcal{H}^2(\psi(t, \Sigma))) \right|_{t=0}.$$

If $[\delta V](\chi) = 0$ for every $\chi \in C_c^{\infty}(U, TU)$, then V is said to be *stationary in U* . Thus stationary varifolds are natural generalizations of minimal surfaces.

Stationary varifolds in Euclidean spaces satisfy the monotonicity formula (see sections 17 and 40 of [18]):

$$\text{For every } x \text{ the function } f(\rho) = \frac{\|V\|(B_{\rho}(x))}{\pi \rho^2} \text{ is non-decreasing.} \quad (1.2)$$

When V is a stationary varifold in a Riemannian manifold a similar formula with an error term holds. Namely, there exists a constant $C(r) \geq 1$ such that

$$f(s) \leq C(r) f(\rho) \quad \text{whenever } 0 < s < \rho < r. \quad (1.3)$$

Moreover, the constant $C(r)$ approaches 1 as $r \downarrow 0$. This property allows us to define the *density* of a stationary varifold V at x , by

$$\theta(x, V) = \lim_{r \downarrow 0} \frac{\|V\|(B_r(x))}{\pi r^2}.$$

Thus $\theta(x, V)$ corresponds to the upper density θ^{*2} of the measure $\|V\|$ as defined in section 3 of [18].

1.4. Curvature estimates for stable minimal surfaces. In many of the proofs we will use Schoen's curvature estimate (see [17]) for stable minimal surfaces. Recall that this estimate asserts that, if $U \subset\subset M$, then there exists a universal constant, $C(U)$, such that for every stable minimal surface $\Sigma \subset U$ with $\partial\Sigma \subset \partial U$ and second fundamental form A

$$|A|^2(x) \leq \frac{C(U)}{d^2(x, \partial U)} \quad \forall x \in \Sigma. \quad (1.4)$$

In fact, what we will use is not the actual curvature estimate, rather it is the following consequence of it:

If $\{\Sigma^n\}$ is a sequence of stable minimal surfaces in U , then a subsequence converges to a stable minimal surface Σ^∞ . (1.5)

1.5. Almost minimizing min–max sequences. Next, we assume that Λ is a fixed saturated set and we begin by recalling the building blocks of the proof of Theorem 0.4. First of all, in [8], following ideas of Pitts and Almgren (see [14] and [5]), the authors reported a proof of the following proposition (cp. with Proposition 3.1 in [8]).

Proposition 1.1. *There exists a minimizing sequence $\{\{\Sigma_t\}^n\} \subset \Lambda$ such that every min–max sequence $\{\Sigma_{t_n}^n\}$ clusters to stationary varifolds.*

It is well–known that stationary varifolds are not, in general, smooth minimal surfaces. The regularity theory of Theorem 0.4 relies on the definition of almost minimizing sequence, a concept introduced by Pitts in [14] and based on ideas of Almgren (see [5]). Roughly speaking a surface Σ is almost minimizing if any path of surfaces $\{\Sigma_t\}_{t \in [0,1]}$ starting at Σ and such that Σ_1 has small area (compared to Σ) must necessarily pass through a surface with large area. Our actual definition, following Smith and Simon, is in fact more restrictive: we will require the property above only for families $\{\Sigma_t\}$ given by smooth isotopies.

Definition 1.2. *Given $\varepsilon > 0$, an open set $U \subset M^3$, and a surface Σ , we say that Σ is ε -a.m. in U if there DOES NOT exist any isotopy ψ supported in U such that*

$$\mathcal{H}^2(\psi(t, \Sigma)) \leq \mathcal{H}^2(\Sigma) + \varepsilon/8 \text{ for all } t; \quad (1.6)$$

$$\mathcal{H}^2(\psi(1, \Sigma)) \leq \mathcal{H}^2(\Sigma) - \varepsilon. \quad (1.7)$$

Using a combinatorial argument due to Almgren and exploited by Pitts in [14], the second step of [8] was to show Proposition 1.4 below.

Remark 1.3. *In fact, the statement of Proposition 1.4 does not coincide exactly with the corresponding Proposition 5.1 of [8]. However, it is easy to see that Proposition 5.3 of [8] yields the slightly small precise statement given below.*

Proposition 1.4. *There exists a function $r : M \rightarrow \mathbf{R}^+$ and a min–max sequence $\Sigma^j = \Sigma_{t_j}^j$ such that:*

- *in every annulus A_n centered at x and with outer radius at most $r(x)$, Σ^j is $1/j$ -a.m. provided j is large enough;*
- *In any such annulus, Σ^j is smooth when j is sufficiently large;*

- Σ^j converges to a stationary varifold V in M , as $j \uparrow \infty$.

The following Theorem completed the proof of Theorem 0.4 (cp. with Theorem 7.1 in [8]).

Theorem 1.5. *Let $\{\Sigma^j\}$ be a sequence of surfaces in M and assume the existence of a function $r : M \rightarrow \mathbf{R}^+$ such that the conclusions of Proposition 1.4 hold. Then V is a smooth minimal surface.*

The proof of this Theorem draws heavily on a fundamental result of Meeks, Simon and Yau ([13]). A suitable version of it plays a fundamental role also in this paper and since the modifications of the ideas of [13] needed in our case are complicated, we will discuss them later in detail. From now on, in order to simplify our notation, a sequence $\{\Sigma^j\}$ satisfying the conclusions of Proposition 1.4 will be simply called *almost minimizing in sufficiently small annuli*.

1.6. Statement of the result. Our genus estimate is valid, in general, for limits of sequences of surfaces which are almost minimizing in sufficiently small annuli.

Theorem 1.6. *Let $\Sigma^j = \Sigma_{t_j}^j$ be a sequence which is a.m. in sufficiently small annuli. Let $V = \sum_i n_i \Gamma^i$ be the varifold limit of $\{\Sigma^j\}$, where Γ^i are as in Theorem 0.6. Then*

$$\sum_{\Gamma^i \in \mathcal{O}} \mathbf{g}(\Gamma^i) + \frac{1}{2} \sum_{\Gamma^i \in \mathcal{N}} (\mathbf{g}(\Gamma^i) - 1) \leq \liminf_{j \uparrow \infty} \liminf_{\tau \rightarrow t_j} \mathbf{g}(\Sigma_\tau^j). \tag{1.8}$$

2. OVERVIEW OF THE PROOF

In this section we give an overview of the proof of Theorem 1.6. Therefore we fix a min-max sequence $\Sigma^j = \Sigma_{t_j}^j$ as in Theorem 1.6 and we let $\sum_i n_i \Gamma^i$ be its varifold limit. Consider the smooth surface $\Gamma = \cup_i \Gamma^i$ and let $\varepsilon_0 > 0$ be so small that there exists a smooth retraction of the tubular neighborhood $T_{2\varepsilon_0} \Gamma$ onto Γ . This means that, for every $\delta < 2\varepsilon_0$,

- $T_\delta \Gamma^i$ are smooth open sets with pairwise disjoint closures;
- if Γ^i is orientable, then $T_\delta \Gamma^i$ is diffeomorphic to $\Gamma^i \times]-1, 1[$;
- if Γ^i is non-orientable, then the boundary of $T_\delta \Gamma^i$ is an orientable double cover of Γ^i .

2.1. Simon’s Lifting Lemma. The following Proposition is the core of the genus bounds. Similar statements have been already used in the literature (see for instance [10] and [9]). We recall that the surface Σ^j might not be everywhere regular, and we denote by P_j its set of singular points (possibly empty).

Proposition 2.1 (Simon’s Lifting Lemma). *Let γ be a closed simple curve on Γ^i and let $\varepsilon \leq \varepsilon_0$ be positive. Then, for j large enough, there is a positive $n \leq n_i$ and a closed curve $\tilde{\gamma}^j$ on $\Sigma^j \cap T_\varepsilon \Gamma^i \setminus P_j$ which is homotopic to $n\gamma$ in $T_\varepsilon \Gamma^i$.*

Simon’s lifting Lemma implies directly the genus bounds if we use the characterization of homology groups through integer rectifiable currents and some more geometric measure theory. However, we choose to conclude the proof in a more elementary way, using Proposition 2.3 below.

2.2. Surgery. The idea is that, for j large enough, one can modify any $\{\Sigma_t^j\}$ sufficiently close to $\Sigma^j = \Sigma_{t_j}^j$ through surgery to a new surface $\tilde{\Sigma}_t^j$ such that

- the new surface lies in a tubular neighborhood of Γ ;
- it coincides with the old surface in a yet smaller tubular neighborhood.

The surgeries that we will use in this paper are of two kind: we are allowed to

- remove a small cylinder and replace it by two disks (as in Fig. 2);
- discard a connected component.

We give below the precise definition.

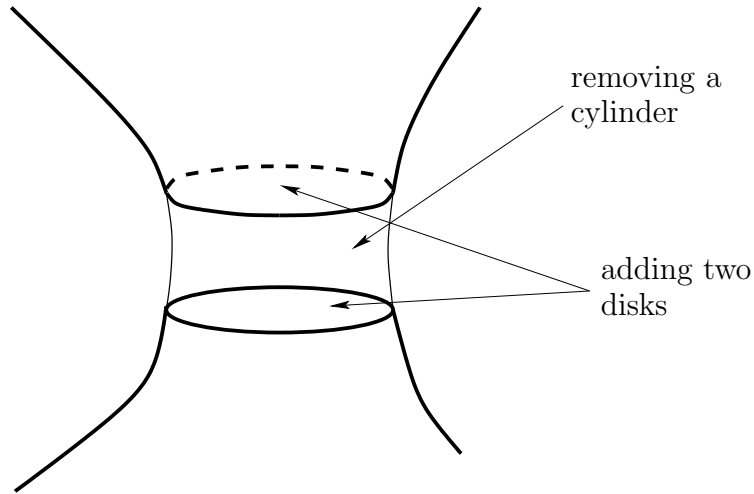

FIGURE 2. Cutting away a neck

Definition 2.2. Let Σ and $\tilde{\Sigma}$ be two closed smooth embedded surfaces. We say that $\tilde{\Sigma}$ is obtained from Σ by cutting away a neck if:

- $\Sigma \setminus \tilde{\Sigma}$ is homeomorphic to $S^1 \times]0, 1[$;
- $\tilde{\Sigma} \setminus \Sigma$ is homeomorphic to the disjoint union of two open disks;
- $\tilde{\Sigma} \Delta \Sigma$ is a contractible sphere.

We say that $\tilde{\Sigma}$ is obtained from Σ through surgery if there is a finite number of surfaces $\Sigma_0 = \Sigma, \Sigma_1, \dots, \Sigma_N = \tilde{\Sigma}$ such that each Σ_k is

- either isotopic to the union of some connected components of Σ_{k-1} ;
- or obtained from Σ_{k-1} by cutting away a neck.

Clearly, if $\tilde{\Sigma}$ is obtained from Σ through surgery, then $\mathbf{g}(\tilde{\Sigma}) \leq \mathbf{g}(\Sigma)$. We are now ready to state our next Proposition.

Proposition 2.3. Let $\varepsilon \leq \varepsilon_0$ be positive. For each j sufficiently large and for t sufficiently close to t_j , we can find a surface $\tilde{\Sigma}_t^j$ obtained from Σ_t^j through surgery and satisfying the following properties:

- $\tilde{\Sigma}_t^j$ is contained in $T_{2\varepsilon}\Gamma$;
- $\tilde{\Sigma}_t^j \cap T_\varepsilon\Gamma = \Sigma_t^j \cap T_\varepsilon\Gamma$.

2.3. Proof of Theorem 1.6. Proposition 2.3 and Proposition 2.1 allow us to conclude the proof of Theorem 1.6. We only need the following standard fact for the first integral homology group of a smooth closed connected surface (see Sections 4.2 and 4.5 of [12]).

Lemma 2.4. *Let Γ be a connected closed 2-dimensional surface with genus \mathbf{g} . If Γ is orientable, then $H^1(\Gamma) = \mathbb{Z}^{2\mathbf{g}}$. If Γ is non-orientable, then $H^1(\Gamma) = \mathbb{Z}^{\mathbf{g}-1} \times \mathbb{Z}_2$.*

The proof of Proposition 2.3 is given below, at the end of this section. The rest of the paper is then dedicated to prove Simon's Lifting Lemma. We now come to the proof of Theorem 1.6.

Proof of Theorem 1.6. Define $m_i = \mathbf{g}(\Gamma^i)$ if i is orientable and $(\mathbf{g}(\Gamma^i) - 1)/2$ if not. Our aim is to show that

$$\sum_i m_i \leq \liminf_{j \uparrow \infty} \liminf_{t \rightarrow t_j} \mathbf{g}(\Sigma_t^j). \quad (2.1)$$

By Lemma 2.4, for each Γ^i there are $2m_i$ curves $\gamma^{i,1}, \dots, \gamma^{i,2m_i}$ with the following property: (Hom) If k_1, \dots, k_{2m_i} are integers such that $k_1\gamma^{i,1} + \dots + k_{2m_i}\gamma^{i,2m_i}$ is homologically trivial in Γ^i , then $k_l = 0$ for every l .

Since $\varepsilon < \varepsilon_0/2$, $T_{2\varepsilon}\Gamma^i$ can be retracted smoothly on Γ^i . Hence:

(Hom') If k_1, \dots, k_{2m_i} are integers such that $k_1\gamma^{i,1} + \dots + k_{2m_i}\gamma^{i,2m_i}$ is homologically trivial in $T_{2\varepsilon}\Gamma^i$, then $k_l = 0$ for every l .

Next, fix $\varepsilon < \varepsilon_0$ and let N be sufficiently large so that, for each $j \geq N$, Simon's Lifting Lemma applies to each curve $\gamma^{i,l}$. We require, moreover, that N is large enough so that Proposition 2.3 applies to every $j > N$.

Choose next any $j > N$ and consider the curves $\tilde{\gamma}^{i,l}$ lying in $T_\varepsilon\Gamma \cap \Sigma^j$ given by Simon's Lifting Lemma. Such surfaces are therefore homotopic to $n_{i,l}\gamma^{i,l}$ in $T_\varepsilon\Gamma^i$, where each $n_{i,l}$ is a positive integer. Moreover, for each t sufficiently close to t_j consider the surface $\tilde{\Sigma}_t^j$ given by Proposition 2.3. The surface $\tilde{\Sigma}_t^j$ decomposes into the finite number of components (not necessarily connected) $\tilde{\Sigma}_t^j \cap T_{2\varepsilon}\Gamma^i$. Each such surface is orientable and

$$\sum_i \mathbf{g}(\tilde{\Sigma}_t^j \cap T_{2\varepsilon}\Gamma^i) = \mathbf{g}(\tilde{\Sigma}_t^j) \leq \mathbf{g}(\Sigma_t^j). \quad (2.2)$$

We claim that

$$m_i \leq \liminf_{t \rightarrow t_j} \mathbf{g}(\tilde{\Sigma}_t^j \cap T_{2\varepsilon}\Gamma^i), \quad (2.3)$$

which clearly would conclude the proof.

Since Σ_t^j converges smoothly to Σ^j outside P_j , we conclude that $\tilde{\Sigma}_t^j \cap T_\varepsilon\Gamma^i$ converges smoothly to $\Sigma^j \cap T_\varepsilon\Gamma^i$ outside P_j . Since each $\gamma^{i,l}$ does not intersect P_j , it follows that, for t large enough, there exist curves $\hat{\gamma}^{i,l}$ contained in $\tilde{\Sigma}_t^j \cap T_\varepsilon\Gamma^i$ and homotopic to $\tilde{\gamma}^{i,l}$ in $T_\varepsilon\Gamma^i$.

Summarizing:

- (i) Each $\tilde{\gamma}^{i,l}$ is homotopic to $n_{i,l}\gamma^{i,l}$ in $T_\varepsilon\Gamma^i$ for some positive integer $n_{i,l}$;
- (ii) Each $\tilde{\gamma}^{i,l}$ is contained in $\tilde{\Sigma}_t^j \cap T_{2\varepsilon}\Gamma^i$;
- (iii) $\tilde{\Sigma}_t^j \cap T_{2\varepsilon}\Gamma^i$ is a closed surface;
- (iv) If $c_1\gamma^{i,1} + \dots + c_{2m_i}\gamma^{i,2m_i}$ is homologically trivial in $T_{2\varepsilon}\Gamma^i$ and the c_l 's are integers, then they are all 0.

These statements imply that:

(Homⁿ) If $c_1\tilde{\gamma}^{i,1} + \dots + c_{2m_i}\tilde{\gamma}^{i,2m_i}$ is homologically trivial in $\tilde{\Sigma}_t^j \cap T_{2\varepsilon}\Gamma^i$ and the c_l 's are integers, then they are all 0.

From Lemma 2.4, we conclude again that $\mathbf{g}(\tilde{\Sigma}_t^j \cap T_{2\varepsilon}\Gamma^i) \geq m_i$. \square

2.4. Proof of Proposition 2.3. Consider the set $\Omega = T_{2\varepsilon}\Gamma \setminus \overline{T_\varepsilon\Gamma}$. Since Σ^j converges, in the sense of varifolds, to Γ , we have

$$\lim_{j \uparrow \infty} \limsup_{t \rightarrow t_j} \mathcal{H}^2(\Sigma_t^j \cap \Omega) = 0. \quad (2.4)$$

Let $\eta > 0$ be a positive number to be fixed later and consider N such that

$$\limsup_{t \rightarrow t_j} \mathcal{H}^2(\Sigma_t^j \cap \Omega) < \eta/2 \quad \text{for each } j \geq N. \quad (2.5)$$

Fix $j \geq N$ and let $\delta_j > 0$ be such that

$$\mathcal{H}^2(\Sigma_t^j \cap \Omega) < \eta \quad \text{if } |t_j - t| < \delta_j. \quad (2.6)$$

For each $\sigma \in]\varepsilon, 2\varepsilon[$ consider $\Delta_\sigma := \partial(T_\sigma\Gamma)$, i.e. the boundary of the tubular neighborhood $T_\sigma\Gamma$. The surfaces Δ_σ are a smooth foliation of $\Omega \setminus \Gamma$ and therefore, by the coarea formula

$$\int_\varepsilon^{2\varepsilon} \text{Length}(\Sigma_t^j \cap \Delta_\sigma) d\sigma \leq C\mathcal{H}^2(\Sigma_t^j \cap \Omega) < C\eta \quad (2.7)$$

where C is a constant independent of t and j . Therefore,

$$\text{Length}(\Sigma_t^j \cap \Delta_\sigma) < \frac{2C\eta}{\varepsilon} \quad (2.8)$$

holds for a set of σ 's with measure at least $\varepsilon/2$.

By Sard's Lemma we can fix a σ such that (2.7) holds and Σ_t^j intersects Δ_t transversally. For positive constants λ and C , independent of j and t , the following holds:

(B) For any $s \in]0, 2\varepsilon[$, any simple closed curve γ lying on Δ_s with $\text{Length}(\gamma) \leq \lambda$ bounds an embedded disk $D \subset \Delta_s$ with $\text{diam}(D) \leq C\text{Length}(\gamma)$.

Assume that $2C\eta/\varepsilon < \lambda$. By construction, $\Sigma_t^j \cap \Delta_\sigma$ is a finite collection of simple curves. Consider $\tilde{\Omega} := T_{\sigma+\delta}\Gamma \setminus \overline{T_{\sigma-\delta}\Gamma}$. For δ sufficiently small, $\tilde{\Omega} \cap \Sigma_t^j$ is a finite collection of cylinders, with upper bases lying on $\Delta_{\sigma+\delta}$ and lower bases lying on $\Delta_{\sigma-\delta}$. We "cut away" this finite number of necks by removing $\tilde{\Omega} \cap \Sigma_t^j$ and replacing them with the two disks lying on $\Delta_{\sigma-\delta} \cup \Delta_{\sigma+\delta}$ and enjoying the bound (B). For a suitable choice of η , the union of each neck and of the corresponding two disks has sufficiently small diameter. This surface is therefore a compressible sphere, which implies that the new surface $\hat{\Sigma}_t^j$ is obtained from Σ_t^j through surgery.

We can smooth it a little: the smoothed surface will still be obtained from Σ_t^j through surgery and will not intersect Δ_σ . Therefore $\tilde{\Sigma}_t^j := \hat{\Sigma}_t^j \cap T_\sigma\Gamma$ is a closed surface and is obtained from $\hat{\Sigma}_t^j$ by dropping a finite number of connected components. \square

3. PROOF OF PROPOSITION 2.1. PART I: MINIMIZING SEQUENCES OF ISOTOPIC SURFACES

A key point in the proof of Simon's Lifting Lemma is Proposition 3.2 below. Its proof, postponed to later sections, relies on the techniques introduced by Almgren and Simon in [4] and Meeks, Simon and Yau in [13]. Before stating the proposition we need to introduce some notation.

3.1. Minimizing sequences of isotopic surfaces.

Definition 3.1. *Let \mathcal{I} be a class of isotopies of M and $\Sigma \subset M$ a smooth embedded surface. If $\{\varphi^k\} \subset \mathcal{I}$ and*

$$\lim_{k \rightarrow \infty} \mathcal{H}^2(\varphi^k(1, \Sigma)) = \inf_{\psi \in \mathcal{I}} \mathcal{H}^2(\psi(1, \Sigma)),$$

then we say that $\varphi^k(1, \Sigma)$ is a minimizing sequence for Problem (Σ, \mathcal{I}) .

If U is an open set of M , Σ a surface with $\partial\Sigma \subset \partial U$ and $j \in \mathbb{N}$ an integer, then we define

$$\mathfrak{Is}_j(U, \Sigma) := \{\psi \in \mathfrak{Is}(U) \mid \mathcal{H}^2(\psi(\tau, \Sigma)) \leq \mathcal{H}^2(\Sigma) + 1/(8j) \quad \forall \tau \in [0, 1]\}. \quad (3.1)$$

Proposition 3.2. *Let $U \subset M$ be an open ball with sufficiently small radius and consider a smooth embedded surface Σ such that $\partial\Sigma \subset \partial U$ is also smooth. Let $\Delta^k := \varphi^k(1, \Sigma)$ be a minimizing sequence for Problem $(\Sigma, \mathfrak{Is}_j(U, \Sigma))$, converging to a stationary varifold V . Then, V is a smooth minimal surface Δ with smooth boundary $\partial\Delta = \partial\Sigma$.*

Moreover, if we form a new sequence $\tilde{\Delta}^k$ by taking an arbitrary union of connected components of Δ^k , it converges, up to subsequences, to the union of some connected components of Δ .

In fact, we believe that the proof of Proposition 3.2 could be modified to include any open set U with smooth, uniformly convex boundary. However, such a statement would imply several technical complications in Section 5 and hence goes beyond our scopes. Instead, the following simpler statement can be proved directly with our arguments, though we do not give the details.

Proposition 3.3. *Let $U \subset M$ be a uniformly convex open set with smooth boundary and consider a smooth embedded surface Σ such that $\partial\Sigma \subset \partial U$ is also smooth. Let $\Delta^k := \varphi^k(1, \Sigma)$ be a minimizing sequence for Problem $(\Sigma, \mathfrak{Is}(U))$, converging to a stationary varifold V . Then, V is a smooth minimal surface Δ with smooth boundary $\partial\Delta = \partial\Sigma$.*

Moreover, if we form a new sequence $\tilde{\Delta}^k$ by taking an arbitrary union of connected components of Δ^k , it converges, up to subsequences, to the union of some connected components of Δ .

3.2. Elementary remarks on minimizing surfaces. We end this section by collecting some properties of minimizing sequences of isotopic surfaces which will be used often throughout this paper. We start with two very elementary remarks.

Remark 3.4. *If Σ is $1/j$ -a.m. in an open set U and \tilde{U} is an open set contained in U , then Σ is $1/j$ -a.m. in \tilde{U} .*

Remark 3.5. *If Σ is $1/j$ -a.m. in U and $\psi \in \mathfrak{Is}_j(\Sigma, U)$ is such that $\mathcal{H}^2(\psi(1, \Sigma)) \leq \mathcal{H}^2(\Sigma)$, then $\psi(1, \Sigma)$ is $1/j$ -a.m. in U .*

Next we collect two lemmas. Their proofs are short and we include them below for the reader's convenience.

Lemma 3.6. *Let Σ_j be $1/j$ -a.m. in annuli and $r : M \rightarrow \mathbf{R}^+$ be the function of Theorem 1.5. Assume U is an open set with closure contained in $\text{An}(x, \tau, \sigma)$, where $\sigma < r(x)$. Let $\psi_j \in \mathfrak{Is}_j(\Sigma_j, U)$ be such that $\mathcal{H}^2(\psi_j(1, \Sigma_j)) \leq \mathcal{H}^2(\Sigma)$. Then $\psi_j(1, \Sigma_j)$ is $1/j$ -a.m. in sufficiently small annuli.*

Proof. Recall the definition of $1/j$ -a.m. in sufficiently small annuli. This means that there is a function $r : M \rightarrow \mathbf{R}^+$ such that Σ is $1/j$ -a.m. on every annulus centered at y and with outer radius smaller than $r(y)$. Let $\text{An}(x, \tau, \sigma)$ be an annulus on which Σ is $1/j$ -a.m. and $U \subset\subset \text{An}(x, \tau, \sigma)$. If $y \notin B_\sigma(x)$, then $\text{dist}(y, U) > 0$. Set $r_1(y) := \min\{r(y), \text{dist}(y, U)\}$. Then $\psi(1, \Sigma) = \Sigma$ on every annulus with center y and radius smaller than $r_1(y)$, and therefore it is $1/j$ -a.m. in it. If $y = x$, then the statement is obvious because of Remark 3.5. If $y \in B_\sigma(x) \setminus \{x\}$, then there exists $\rho(y), \tau(y)$ such that $U \cup B_{\rho(y)}(y) \subset \text{An}(x, \tau(y), \sigma)$. By Remarks 3.5 and 3.4, $\psi(1, \Sigma)$ is $1/j$ -a.m. on every annulus centered at y and outer radius smaller than $\rho(y)$. \square

Lemma 3.7. *Let $\{\Sigma^j\}$ be a sequence as in Theorem 1.5 and U and ψ_j be as in Lemma 3.6. Assume moreover that U is contained in a convex set W . If Σ^j converges to a varifold V , then $\psi_j(1, \Sigma^j)$ converges as well to V .*

Proof of Lemma 3.7. By Theorem 1.5 V is a smooth minimal surface (multiplicity allowed). By Lemma 3.6, $\psi_j(1, \Sigma^j)$ is also $1/j$ -a.m. and again by Theorem 1.5 a subsequence (not relabeled) converges to a varifold V' which is a smooth minimal surface. Since $\Sigma^j = \psi_j(1, \Sigma^j)$ outside W , $V = V'$ outside W . Being W convex, it cannot contain any closed minimal surface, and hence by standard unique continuation, $V = V'$ in W as well. \square

4. PROOF OF PROPOSITION 2.1. PART II: LEAVES

4.1. Step 1. Preliminaries. Let $\{\Sigma^j\}$ be a sequence as in Theorem 1.6. We keep the convention that Γ denotes the union of disjoint closed connected embedded minimal surfaces Γ^i (with multiplicity 1) and that Σ^j converges, in the sense of varifolds, to $V = \sum_i n_i \Gamma^i$. Finally, we fix a curve γ contained in Γ .

Let $r : \Gamma \rightarrow \mathbf{R}^+$ be such that the three conclusions of Proposition 1.4 hold. Consider a finite covering $\{B_{\rho_l}(x_l)\}$ of M with $\rho_l < r(x_l)$ and denote by C the set of the centers $\{x_l\}$. Next, up to extraction of subsequences, we assume that the set of singular points $P_j \subset \Sigma^j$ converges in the sense of Hausdorff to a finite set P (recall Remark 0.2) and we denote by E the union of C and P . Recalling Remark 3.4, for each $x \in M \setminus E$ there exists a ball B centered at x such that:

- $\Sigma^j \cap B$ is a smooth surface for j large enough;
- Σ^j is $1/j$ -a.m. in B for j large enough.

Deform γ to a smooth curve contained in $\Gamma \setminus E$ and homotopic to γ in Γ . It suffices to prove the claim of the Proposition for the new curve. By abuse of notation we continue to denote it by γ . In what follows, we let ρ_0 be any given positive number so small that:

- $T_{\rho_0}(\Gamma)$ can be retracted on Γ ;
- For every $x \in \Gamma$, $B_{\rho_0}(x) \cap \Gamma$ is a disk with diameter smaller than the injectivity radius of Γ .

For any positive $\rho \leq 2\rho_0$ sufficiently small, we can find a finite set of points x_1, \dots, x_N on γ with the following properties (to avoid cumbersome notation we will use the convention $x_{N+1} = x_1$):

- (C1) If we let $[x_k, x_{k+1}]$ be the geodesic segment on Γ connecting x_k and x_{k+1} , then γ is homotopic to $\sum_k [x_k, x_{k+1}]$.
- (C2) $B_\rho(x_{k+1}) \cap B_\rho(x_k) = \emptyset$;
- (C3) $B_\rho(x_k) \cup B_\rho(x_{k+1})$ is contained in a ball $B^{k,k+1}$ of radius 3ρ ;
- (C4) In any ball $B^{k,k+1}$, Σ^j is $1/j$ -a.m. and smooth provided j is large enough;

see Figure 3. From now on we will consider j so large that (C4) holds for every k . The constant ρ will be chosen (very small, but independent of j) only at the end of the proof. The existence of the points x_k is guaranteed by a simple compactness argument if ρ_0 is a sufficiently small number.

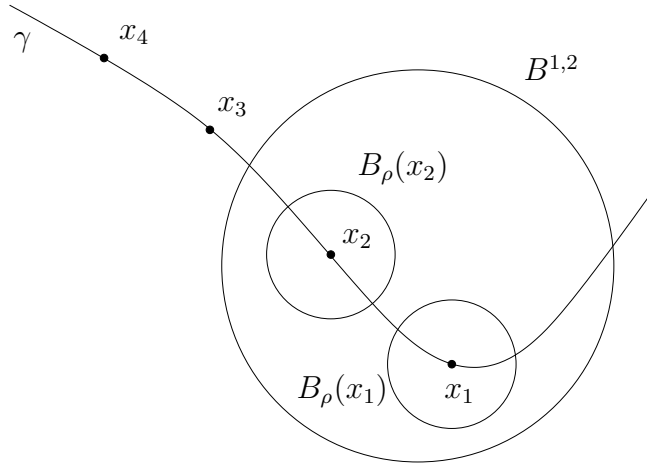

FIGURE 3. The points x_l of (C1)-(C4).

4.2. Step 2. Leaves. In every $B_\rho(x_k)$ consider a minimizing sequence $\Sigma^{j,l} := \psi_l(1, \Sigma^j)$ for Problem $(\Sigma^j, \mathfrak{I}\mathfrak{s}_j(B_\rho(x_k), \Sigma^j))$. Using Proposition 3.2, extract a subsequence converging (in $B_\rho(x_k)$) to a smooth minimal surface $\Gamma^{j,k}$ with boundary $\partial\Gamma^{j,k} = \Sigma^j \cap B_\rho(x_k)$. This is a stable minimal surface, and we claim that, as $j \uparrow \infty$, $\Gamma^{j,k}$ converges smoothly on every ball $B_{(1-\theta)\rho}(x_k)$ (with $\theta < 1$) to V . Indeed, this is a consequence of Schoen's curvature estimates, see Subsection 1.4.

By a diagonal argument, if $\{l_j\}$ grows sufficiently fast, $\Sigma^{j,l_j} \cap B_\rho(x_k)$ has the same limit as $\Gamma^{j,k}$. On the other hand, for $\{l_j\}$ growing sufficiently fast, Lemmas 3.6 and 3.7 apply, giving that Σ^{j,l_j} converges to V .

Therefore, $\Gamma^{j,k}$ converges smoothly to $n_i\Gamma^i \cap B_{(1-\theta)\rho}(x_k)$ in $B_{(1-\theta)\rho}(x_k)$ for every positive $\theta < 1$. Therefore any connected component of $\Gamma^{j,k} \cap B_{(1-\theta)\rho}(x_k)$ is eventually (for large j 's) a disk (multiplicity allowed). The area of such a disk is, by the monotonicity formula for minimal surfaces, at least $c(1-\theta)^2\rho^2$, where c is a constant depending only on M . From now on we consider θ fixed, though its choice will be specified later.

Up to extraction of subsequences, we can assume that for each connected component $\hat{\Sigma}^j$ of Σ^j , $\psi_l(1, \hat{\Sigma}^j)$ converges to a finite union of connected components of $\Gamma^{j,k}$. However, in $B_{(1-\theta)\rho}(x_k)$,

- either their limit is zero;
- or the area of $\psi_l(1, \hat{\Sigma}^j)$ in $B_{(1-\theta)\rho}(x_k)$ is larger than $c(1-2\theta)^2\rho^2$ for l large enough.

We repeat this argument for every k . Therefore, for any j sufficiently large, we define the set $\mathcal{L}(j, k)$ whose elements are those connected components $\hat{\Sigma}^j$ of $\Sigma^j \cap B_\rho(x_k)$ such that $\psi_l(1, \hat{\Sigma}^j)$ intersected with $B_{(1-\theta)\rho}(x_k)$ has area at least $c(1-2\theta)^2\rho^2$.

Recall that Σ^j is converging to $n_i\Gamma^i \cap B_\rho(x_k)$ in $B_\rho(x_k)$ in the sense of varifolds. Therefore, the area of Σ^j is very close to $n_i\mathcal{H}^2(\Gamma^i \cap B_\rho(x_k))$. On the other hand, by definition $\mathcal{H}^2(\psi_l(1, \Sigma^j) \cap B_\rho(x_k))$ is not larger. This gives a bound to the cardinality of $\mathcal{L}(j, k)$, independent of j and k . Moreover, if ρ and θ are sufficiently small, the constants c and ε get so close, respectively, to 1 and 0 that the cardinality of $\mathcal{L}(j, k)$ can be at most n_i .

4.3. Step 3. Continuation of the leaves. We claim the following

Lemma 4.1 (Continuation of the leaves). *If ρ is sufficiently small, then for every j sufficiently large and for every element Λ of $\mathcal{L}(j, k)$ there is an element $\tilde{\Lambda}$ of $\mathcal{L}(j, k+1)$ such that Λ and $\tilde{\Lambda}$ are contained in the same connected component of $\Sigma^j \cap B^{k, k+1}$.*

The lemma is sufficient to conclude the proof of the Theorem. Indeed let $\{\Lambda_1, \Lambda_2, \dots, \Lambda_k\}$ be the elements of $\mathcal{L}(j, 1)$. Choose a point y_1 on Λ_1 and then a point y_2 lying on an element $\tilde{\Lambda}$ of $\mathcal{L}(j, 2)$ such that $\Lambda_1 \cup \tilde{\Lambda}$ is contained in a connected component of $\Sigma^j \cap B^{1,2}$. We proceed by induction and after N steps we get a point y_{N+1} in some Λ_k . After repeating at most $n_i + 1$ times this procedure, we find two points y_{lN+1} and y_{rN+1} belonging to the same Λ_s . Without loss of generality we discard the first lN points and renumber the remaining ones so that we start with y_1 and end with $y_{nN+1} = y_1$. Note that $n \leq n_i$. Each pair y_k, y_{k+1} can be joined with a path $\gamma_{k, k+1}$ lying on Σ^j and contained in a ball of radius 3ρ , and the same can be done with a path $\gamma_{nN+1, 1}$ joining y_{nN+1} and y_1 . Thus, if we let

$$\tilde{\gamma} = \sum_k \gamma_{k, k+1} + \gamma_{nN+1, 1}$$

we get a closed curve contained in Σ^j .

It is easy to show that the curve $\tilde{\gamma}$ is homotopic to $n\gamma$ in $\cup_k B^{k, k+1}$. Indeed, for each $sN+r$ fix a path $\eta^{sN+r} : [0, 1] \rightarrow B_\rho(x_r)$ with $\eta^{sN+r}(0) = y_{sN+r}$ and $\eta^{sN+r}(1) = x_r$. Next fix an homotopy $\zeta^{sN+r} : [0, 1] \times [0, 1] \rightarrow B^{k, k+1}$ with

- $\zeta^{sN+r}(0, \cdot) = \gamma_{sN+r, sN+r+1}$,
- $\zeta^{sN+r}(1, \cdot) = [x_r, x_{r+1}]$,
- $\zeta^{sN+r}(\cdot, 0) = \eta^{sN+r}(\cdot)$
- and $\zeta^{sN+r}(\cdot, 1) = \eta^{sN+r+1}(\cdot)$.

Joining the $\zeta^{k\gamma}$'s we easily achieve an homotopy between γ and $\tilde{\gamma}$. See Figure 4. If ρ is chosen sufficiently small, then $\cup_k B^{k, k+1}$ is contained in a retractible tubular neighborhood of Γ and does not intersect E .

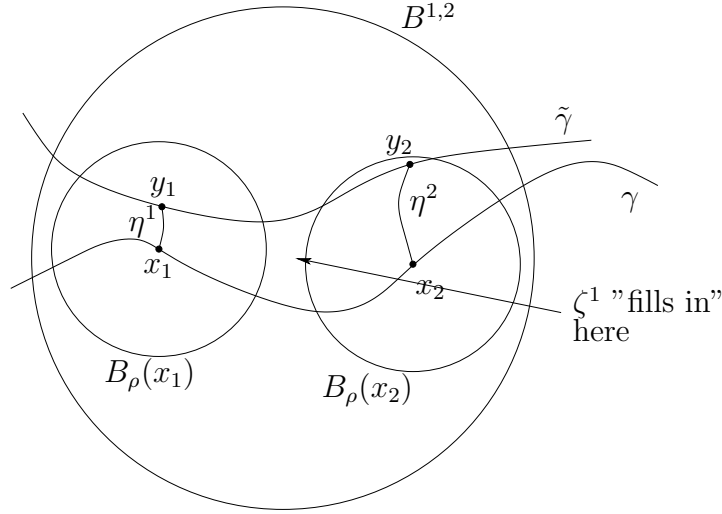
 FIGURE 4. The homotopies ζ^{iN+r} .

4.4. Step 4. Proof of the Continuation of the Leaves. Let us fix a ρ for which Lemma 4.1 does not hold. Our goal is to show that for ρ sufficiently small, this leads to a contradiction. Clearly, there is an integer k and a subsequence $j_l \uparrow \infty$ such that the statement of the Lemma fails. Without loss of generality we can assume $k = 1$ and we set $x = x_1$, $y = x_2$ and $B^{1,2} = B$. Moreover, by a slight abuse of notation we keep labeling Σ^{j_i} as Σ^j .

Consider the minimizing sequence of isotopies $\{\psi_l\}$ for Problem $(\Sigma^j, \mathfrak{I}\mathfrak{s}_j(B_\rho(x), \Sigma^j))$ and $\{\phi_l\}$ for Problem $(\Sigma^j, \mathfrak{I}\mathfrak{s}_j(B_\rho(y), \Sigma^j))$ fixed in Step 3. Since $B_\rho(x) \cap B_\rho(y) = \emptyset$ and ψ_l and ϕ_l leave, respectively, $M \setminus B_\rho(y)$ and $M \setminus B_\rho(x)$ fixed, we can combine the two isotopies in

$$\Phi_l(t, z) := \begin{cases} \psi_l(2t, z) & \text{for } t \in [0, 1/2] \\ \phi_l(2t - 1, z) & \text{for } t \in [1/2, 1]. \end{cases}$$

If we consider $\Sigma^{j,l} = \Phi_l(1, \Sigma^j)$, then $\Sigma^{j,l} \cap B_\rho(x) = \psi_l(1, \Sigma^j) \cap B_\rho(x)$ and $\Sigma^{j,l} \cap B_\rho(y) = \phi_l(1, \Sigma^j) \cap B_\rho(y)$. Moreover for a sufficiently large l , the surface $\Sigma^{j,l}$ by Lemma 3.6 is $1/j$ -a.m. in B and in sufficiently small annuli.

Arguing as in Step 2 (i.e. applying Theorem 1.5, Lemma 3.6 and Lemma 3.7), without loss of generality we can assume that:

- (i) $\Sigma^{j,l}$ converges, as $l \uparrow \infty$, to smooth minimal surfaces Δ^j and Λ^j respectively in $B_\rho(x)$ and $B_\rho(y)$;
- (ii) Δ^j and Λ^j converge, respectively, to $n_i \Gamma^i \cap B_\rho(x)$ and $n_i \Gamma^i \cap B_\rho(y)$;
- (iii) For l_j growing sufficiently fast, Σ^{j,l_j} converges to the varifold $V = \sum_i n_i \Gamma^i$.

Let $\hat{\Sigma}^j$ be the connected component of $\Sigma^j \cap B_\rho(x)$ which contradicts Lemma 4.1. Denote by $\tilde{\Sigma}^j$ the connected component of $B \cap \Sigma^j$ containing $\hat{\Sigma}^j$.

Now, by Proposition 3.2, $\Phi_l(1, \tilde{\Sigma}^j) \cap B_\rho(x)$ converges to a stable minimal surface $\tilde{\Delta}^j \subset \Delta^j$ and $\Phi_l(1, \hat{\Sigma}^j)$ converges to a stable minimal surface $\hat{\Delta}^j \subset \tilde{\Delta}^j$. Because of (ii) and of curvature estimates (see Subsection 1.4), $\hat{\Delta}^j$ converges necessarily to $r \Gamma^i \cap B_\rho(x)$ for some integer $r \geq 0$. Since $\hat{\Sigma}^j \in \mathcal{L}(j, 1)$, it follows that $r \geq 1$. Similarly, $\Phi_l(1, \tilde{\Sigma}^j) \cap B_\rho(y)$ converges to a smooth

minimal surface $\tilde{\Lambda}^j$ and $\tilde{\Lambda}^j$ converges to $s\Gamma^i \cap B_\rho(y)$ for some integer $s \geq 0$. Since $\tilde{\Sigma}^j$ does not contain any element of $\mathcal{L}(j, 2)$, it follows necessarily $s = 0$.

Consider now the varifold W which is the limit in B of $\tilde{\Sigma}^{j,l_j} = \Phi_{l_j}(1, \tilde{\Sigma}^j)$. Arguing again as in Step 2 we choose $\{l_j\}$ growing so fast that W , which is the limit of $\tilde{\Sigma}^{j,l_j}$, coincides with the limit of $\tilde{\Delta}^j$ in $B_\rho(x)$ and with the limit of $\tilde{\Lambda}^j$ in $B_\rho(y)$. According to the discussion above, V coincides then with $r\Gamma^i \cap B_\rho(x)$ in $B_\rho(x)$ and vanishes in $B_\rho(y)$. Moreover

$$\|W\| \leq \|V\| \llcorner B = n\mathcal{H}^2 \llcorner \Gamma^i \cap B \quad (4.1)$$

in the sense of varifolds. We recall here that $\|W\|$ and $\|V\| \llcorner B$ are nonnegative measures defined in the following way:

$$\int \varphi(x) d\|W\|(x) = \lim_{j \uparrow \infty} \int_{\tilde{\Sigma}^{j,l_j}} \varphi \quad (4.2)$$

and

$$\int \varphi(x) d\|V\|(x) = \lim_{j \uparrow \infty} \int_{\Sigma^{j,l_j}} \varphi \quad (4.3)$$

for every $\varphi \in C_c(B)$. Therefore (4.1) must be understood as a standard inequality between measures, which is an effect of (4.2), (4.3) and the inclusion $\tilde{\Sigma}^{j,l_j} \subset \Sigma^{j,l_j} \cap B$. An important consequence of (4.1) is that

$$\|W\|(\partial B_\tau(w)) = 0 \quad \text{for every ball } B_\tau(w) \subset B. \quad (4.4)$$

Next, consider the geodesic segment $[x, y]$ joining x and y in Γ^i . For $z \in [x, y]$, $B_{\rho/2}(z) \subset B$. Moreover,

$$\text{the map } z \mapsto \|W\|(B_{\rho/2}(z)) \text{ is continuous in } z, \quad (4.5)$$

because of (4.1) and (4.4).

Since $\|W\|(B_{\rho/2}(x)) \geq \mathcal{H}^2(\Gamma^i \cap B_{\rho/2}(x))$ and $\|W\|(B_{\rho/2}(y)) = 0$, by the continuity of the map in (4.5), there exists $z \in [x, y]$ such that

$$\|W\|(B_{\rho/2}(z)) = \frac{1}{2}\mathcal{H}^2(\Gamma^i \cap B_{\rho/2}(z)).$$

Since $\|W\|(\partial B_{\rho/2}(z)) = 0$, we conclude (see Proposition 1.62(b) of [6]) that

$$\lim_{j \uparrow \infty} \mathcal{H}^2(\tilde{\Sigma}^{j,l_j} \cap B_{\rho/2}(z)) = \frac{1}{2}\mathcal{H}^2(\Gamma^i \cap B_{\rho/2}(z)) \quad (4.6)$$

(see Figure 5).

On the other hand, since Σ^{j,l_j} converges to V in the sense of varifolds and $V = n_i\Gamma^i \cap B_{\rho/2}(z)$ in $B_{\rho/2}(z)$, we conclude that

$$\lim_{j \uparrow \infty} \mathcal{H}^2((\Sigma^{j,l_j} \setminus \tilde{\Sigma}^{j,l_j}) \cap B_{\rho/2}(z)) = \left(n_i - \frac{1}{2}\right) \mathcal{H}^2(\Gamma^i \cap B_{\rho/2}(z)). \quad (4.7)$$

If ρ is sufficiently small, $\Gamma^i \cap B_{\rho/2}(z)$ is close to a flat disk and $B_{\rho/2}(z)$ is close to a flat ball.

Using the coarea formula and Sard's lemma, we can find a $\sigma \in]0, \rho/2[$ and a subsequence of $\{\Sigma^{j,l_j}\}$ (not relabeled) with the following properties:

- (a) Σ^{j,l_j} intersects $\partial B_\sigma(z)$ transversally;
- (b) $\text{Length}(\tilde{\Sigma}^{j,l_j} \cap \partial B_\sigma(z)) \leq 2(1/2 + \varepsilon)\pi\sigma$;
- (c) $\text{Length}((\Sigma^{j,l_j} \setminus \tilde{\Sigma}^{j,l_j}) \cap \partial B_\sigma(z)) \leq 2((n_i - 1/2) + \varepsilon)\pi\sigma$;

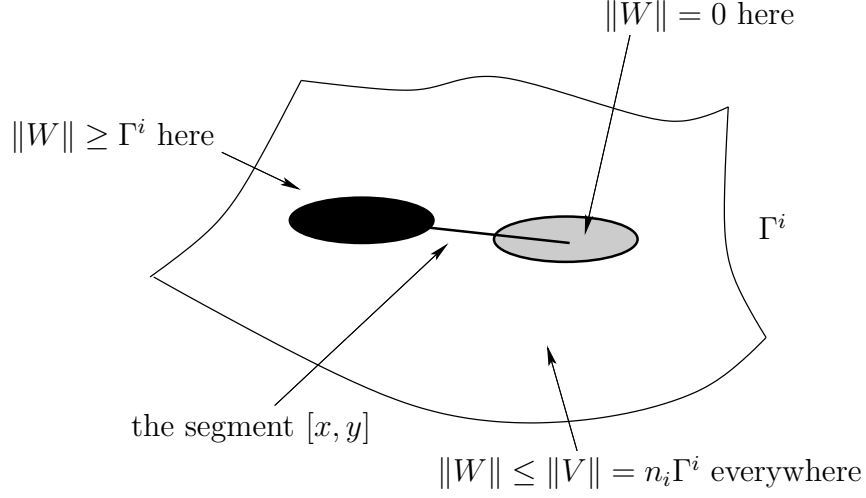
 FIGURE 5. The varifold W .

$$(d) \mathcal{H}^2(\Gamma^i \cap B_\sigma(z)) \geq (1 - \varepsilon)\pi\sigma^2.$$

Note that the geometric constant ε can be made as close to 0 as we want by choosing ρ sufficiently small.

In order to simplify the notation, set $\Omega^j = \Sigma^{j,l_j}$. Consider a minimizing sequence $\Omega^{j,s} = \varphi_s(1, \Omega^j)$ for Problem $(\Omega^j, \mathfrak{I}_{\mathfrak{s}_j}(B_\sigma(z), \Omega^j))$. By Proposition 3.2, $\Omega^{j,s} \cap B_\sigma(z)$ converges, up to subsequences, to a minimal surface Ξ^j with boundary $\Omega^j \cap \partial B_\sigma(z)$. Moreover, using Lemma 3.7 and arguing as in the previous steps, we conclude that Ξ^j converges to $n_i \Gamma^i \cap B_\sigma(z)$.

Next, set:

- $\tilde{\Omega}^j = \tilde{\Sigma}^{j,l_j} \cap B_\sigma(z)$, $\tilde{\Omega}^{j,s} = \varphi_s(1, \tilde{\Omega}^j)$;
- $\hat{\Omega}^j = (\Sigma^{j,l_j} \setminus \tilde{\Sigma}^{j,l_j}) \cap B_\sigma(z)$, $\hat{\Omega}^{j,s} = \varphi_s(1, \hat{\Omega}^j)$.

By Proposition 3.2, since $\tilde{\Omega}^j$ and $\hat{\Omega}^j$ are unions of connected components of $\Omega^j \cap B_\sigma(z)$, we can assume that $\tilde{\Omega}^{j,s}$ and $\hat{\Omega}^{j,s}$ converge respectively to stable minimal surfaces $\tilde{\Xi}^j$ and $\hat{\Xi}^j$ with

$$\partial \tilde{\Xi}^j = \tilde{\Sigma}^{j,l_j} \cap \partial B_\sigma(z) \quad \partial \hat{\Xi}^j = (\Sigma^{j,l_j} \setminus \tilde{\Sigma}^{j,l_j}) \cap \partial B_\sigma(z).$$

Hence, by (b) and (c), we have

$$\text{Length}(\partial \tilde{\Xi}^j) \leq 2 \left(\frac{1}{2} + \varepsilon \right) \pi \sigma \quad \text{Length}(\partial \hat{\Xi}^j) \leq 2 \left(n_i - \frac{1}{2} + \varepsilon \right) \pi \sigma. \quad (4.8)$$

On the other hand, using the standard monotonicity estimate of Lemma 4.2 below, we conclude that

$$\mathcal{H}^2(\hat{\Xi}^j) \leq \left(n_i - \frac{1}{2} + \eta \right) \pi \sigma^2 \quad (4.9)$$

$$\mathcal{H}^2(\tilde{\Xi}^j) \leq \left(\frac{1}{2} + \eta \right) \pi \sigma^2. \quad (4.10)$$

As the constant ε in (d), η as well can be made arbitrarily small by choosing ρ suitably small. We therefore choose ρ so small that

$$\mathcal{H}^2(\hat{\Xi}^j) \leq \left(n_i - \frac{3}{8}\right) \pi \sigma^2, \quad (4.11)$$

$$\mathcal{H}^2(\tilde{\Xi}^j) \leq \frac{5}{8} \pi \sigma^2 \quad (4.12)$$

and

$$\mathcal{H}^2(\Gamma^i \cap B_\sigma(z)) \geq \left(1 - \frac{1}{8n_i}\right) \pi \sigma^2. \quad (4.13)$$

Now, by curvature estimates (see Subsection 1.4), we can assume that the stable minimal surfaces $\tilde{\Xi}^j$ and $\hat{\Xi}^j$, are converging smoothly (on compact subsets of $B_\sigma(z)$) to stable minimal surfaces $\tilde{\Xi}$ and $\hat{\Xi}$. Since $\Xi^j = \tilde{\Xi}^j + \hat{\Xi}^j$ converges to $n_i \Gamma^i \cap B_\sigma(z)$, we conclude that $\tilde{\Xi} = \tilde{n} \Gamma^i \cap B_\sigma(z)$ and $\hat{\Xi} = \hat{n} \Gamma^i \cap B_\sigma(z)$, where \tilde{n} and \hat{n} are nonnegative integers with $\tilde{n} + \hat{n} = n_i$. On the other hand, by (4.11), (4.12) and (4.13), we conclude

$$\tilde{n} \left(1 - \frac{1}{8n_i}\right) \pi \sigma^2 = \mathcal{H}^2(\tilde{\Xi}) \leq \liminf_j \mathcal{H}^2(\tilde{\Xi}^j) \leq \frac{5}{8} \pi \sigma^2 \quad (4.14)$$

$$\hat{n} \left(1 - \frac{1}{8n_i}\right) \pi \sigma^2 = \mathcal{H}^2(\hat{\Xi}) \leq \liminf_j \mathcal{H}^2(\hat{\Xi}^j) \leq \left(n_i - \frac{3}{8}\right) \pi \sigma^2. \quad (4.15)$$

From (4.14) and (4.15) we conclude, respectively, $\tilde{n} = 0$ and $\hat{n} \leq n_i - 1$, which contradicts $\tilde{n} + \hat{n} = n_i$.

4.5. A simple estimate. The following lemma is a standard fact in the theory of minimal surfaces.

Lemma 4.2. *There exist constants C and $r_0 > 0$ (depending only on M) such that*

$$\mathcal{H}^2(\Sigma) \leq \left(\frac{1}{2} + C\sigma\right) \sigma \text{Length}(\partial\Sigma) \quad (4.16)$$

for any $\sigma < r_0$ and for any smooth minimal surface Σ with boundary $\partial\Sigma \subset \partial B_\sigma(z)$.

Indeed, (4.16) follows from the usual computations leading to the monotonicity formula. However, since we have not found a reference for (4.16) in the literature, we will sketch a proof in Appendix A.

5. PROOF OF PROPOSITION 3.2. PART I: CONVEX HULL PROPERTY

5.1. Preliminary definitions. Consider an open geodesic ball $U = B_\rho(\xi)$ with sufficiently small radius ρ and a subset $\gamma \subset \partial U$ consisting of finitely many disjoint smooth Jordan curves.

Definition 5.1. *We say that an open subset $A \subset U$ meets ∂U in γ transversally if there exists a positive angle θ_0 such that:*

- (a) $\partial A \cap \partial U \subset \gamma$.
- (b) For every $p \in \partial A \cap \partial U$ we choose coordinates (x, y, z) in such a way that the tangent plane T_p of ∂U at p is the xy -plane and $\gamma'(p) = (1, 0, 0)$. Then in this setting every point $q = (q_1, q_2, q_3) \in A$ satisfies $\frac{q_3}{q_2} \geq \tan\left(\frac{1}{2} - \theta_0\right)$.

Remark 5.2. Condition (b) of the above definition can be stated in the following geometric way: there exist two halfplanes π_1 and π_2 meeting at the line through p in direction $\gamma'(p)$ such that

- they form an angle θ_0 with T_p ;
- the set A is all contained in the wedge formed by π_1 and π_2 ;

see Figure 6.

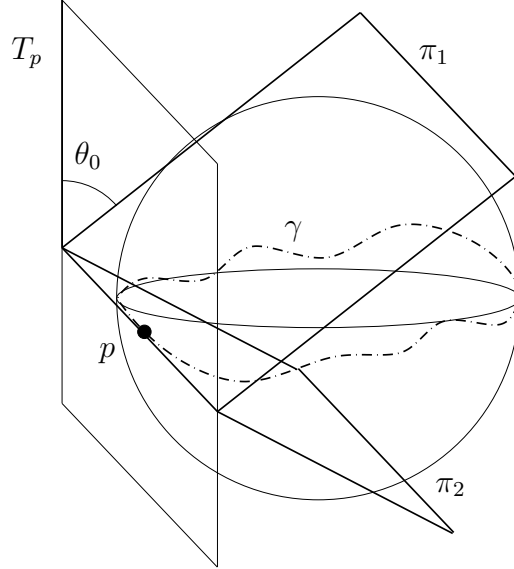

FIGURE 6. For any $p \in A \cap \partial U$, A is contained in a wedge delimited by two halfplanes meeting at p transversally to the plane T_p .

In this section we will show the following lemma.

Lemma 5.3 (Convex hull property). *Let V and Σ be as in Proposition 3.2. Then, there exists a convex open set $A \subset U$ which intersects U in $\partial\Sigma$ transversally and such that $\text{supp}(\|V\|) \subset \overline{A}$.*

Our starting point is the following elementary fact about convex hulls of smooth curves lying in the euclidean two-sphere.

Proposition 5.4. *If $\beta \subset \partial\mathcal{B}_1 \subset \mathbf{R}^3$ is the union of finitely many C^2 -Jordan curves, then its convex hull meets \mathcal{B}_1 transversally in β .*

The proof of this proposition follows from the regularity and the compactness of β and from the fact that β is not self-intersecting. We leave its details to the reader.

5.2. Proof of Lemma 5.3. From now on, we consider $\gamma = \partial\Sigma$: this is the union of finitely many disjoint smooth Jordan curves contained in ∂U . Recall that U is a geodesic ball $B_\rho(\xi)$. Without loss of generality we assume that ρ is smaller than the injectivity radius.

Step 1 Consider the rescaled exponential coordinates induced by the chart $f : \overline{B}_\rho(\xi) \rightarrow \overline{\mathcal{B}}_1$ given by $f(z) = (\exp_\xi^{-1}(z))/\rho$. These coordinates will be denoted by (x_1, x_2, x_3) . We apply

Proposition 5.4 and consider the convex hull B of $\beta = f(\partial\Sigma)$ in \mathcal{B}_1 . According to our definition, $f^{-1}(B)$ meets U transversally in γ .

We now let θ_0 be a positive angle such that condition (b) in Definition 5.1 is fulfilled for B . Next we fix a point $x \in f(\gamma)$ and consider the halfplanes π_1 and π_2 delimiting the wedge of condition (b). Without loss of generality, we can assume that the coordinates are chosen so that π_1 is given by

$$\pi_1 = \{(z_1, z_2, z_3) : z_3 \leq a\}$$

for some positive constant a . Condition (b) ensures that $a \leq a_0 < 1$ for some constant a_0 independent of the point $x \in f(\gamma)$.

For $t \in]0, \infty[$ denote by C_t the points $C_t := \{(0, 0, -t)\}$ and by $r(t)$ the positive real numbers

$$r(t) := \sqrt{1 + t^2 + 2at}$$

We finally denote by R_t the closed balls

$$R_t := \overline{B}_{r(t)}(C_t).$$

The centers C_t and the radii $r(t)$ are chosen in such a way that the intersection of the sphere ∂R_t and $\partial\mathcal{B}_1$ is always the circle $\pi_1 \cap \partial\mathcal{B}_1$.

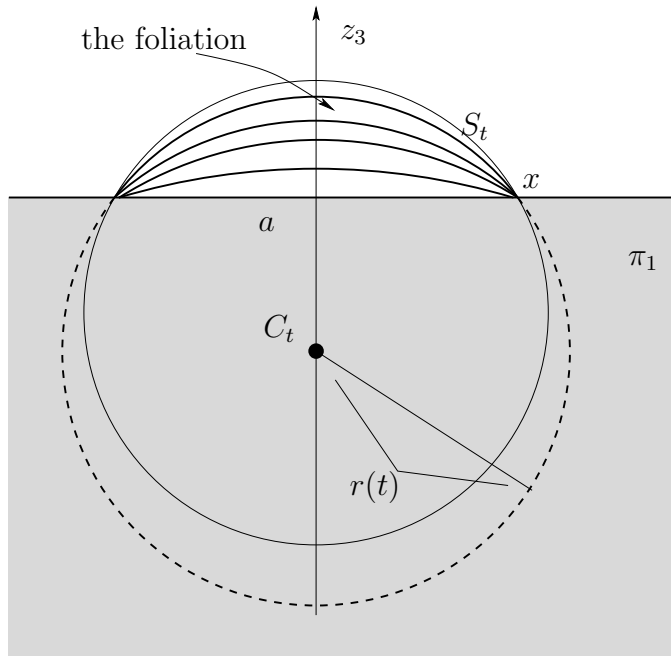

FIGURE 7. A planar cross-section of the foliation $\{S_t : t \in]0, \infty[\}$.

Note, moreover, that for t covering to $+\infty$, the ball R_t converges towards the region $\{z_3 \leq a\}$. Therefore, the region $\{z_3 > a\} \cap \mathcal{B}_1$ is foliated with the caps

$$S_t := \partial R_t \cap \mathcal{B}_1 \quad \text{for } t \in]0, \infty[.$$

In Figure 7, we see a section of this foliation with the plane z_2z_3 .

We claim that, for some constant $t_0 > 0$ independent of the choice of the point $x \in f(\gamma)$, the varifold V is supported in $f^{-1}(R_{t_0})$. A symmetric procedure can be followed starting from the plane π_2 . In this way we find two off-centered balls and hence a corresponding wedge W_x satisfying condition (b) of Definition 5.1 and containing the support of V ; see Picture 8. Our claim that the constant t_0 can be chosen independently of x and the bound $a \leq a_0 < 1$ imply that the the planes delimiting the wedge W_x form an angle larger than some fixed constant with the plane T_x tangent to $\partial\mathcal{B}_1$ at x . Therefore, the intersections of all the wedges W_x , for x varying among the points of γ , yield the desired set A .

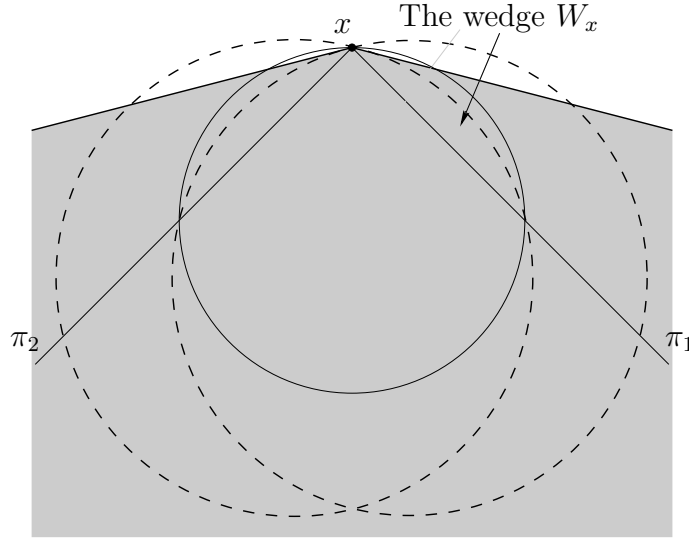

FIGURE 8. A planar cross-section of the wedge W_x .

Step 2 We next want to show that the varifold V is supported in the closed ball $f^{-1}(R_{t_0})$. For any $t \in [0, t_0[$, denote by $\pi_t : \overline{U} \rightarrow f^{-1}(R_t)$ the nearest point projection. If the radius ρ_0 of U and the parameter t_0 are both sufficiently small, then π_t is a well defined Lipschitz map (because there exists a unique nearest point). Moreover, the Lipschitz constant of π_t is equal to 1 and, for $t > 0$, $|\nabla\pi_t| < 1$ on $U \setminus f^{-1}(R_t)$. In fact the following lemma holds.

Lemma 5.5. *Consider in the euclidean ball \mathcal{B}_1 a set U that is uniformly convex, with constant c_0 . Then there is a $\rho(c_0) > 0$ such that, if $\rho_0 \leq \rho(c_0)$, then the nearest point projection π on $f(U)$ is a Lipschitz map with constant 1. Moreover, at every point $P \notin f(U)$, $|\nabla\pi(P)| < 1$.*

The proof is elementary and we give it in Appendix B for the reader's convenience. Next, it is obvious that π_0 is the identity map and that the map $(t, x) \mapsto \pi_t(x)$ is smooth.

Assume now for a contradiction that V is not supported in $f^{-1}(R_{t_0})$. By Lemma 5.5, the varifold $(\pi_{t_0})_{\#}V$ has, therefore, strictly less mass than the varifold V .

Next, consider a minimizing sequence Δ^k as in the statement of proposition 3.2. Since $\partial\Delta^k = \partial\Sigma$, the intersection of Δ^k with ∂U is given by $\partial\Sigma$. On the other hand, by construction $\partial\Sigma \subset f^{-1}(R_t)$ and therefore, if we consider $\Delta_t^k := (\pi_t)_{\#}\Delta^k$ we obtain a (continuous) one-parameter family of currents with the properties that

- (i) $\partial\Delta_t^k = \partial\Sigma$;
- (ii) $\Delta_0^k = \Delta_0$;
- (iii) The mass of Δ_t^k is less or equal than $\mathcal{H}^2(\Delta^k)$;
- (iv) The mass of $\Delta_{t_0}^k$ converges towards the mass of $(\pi_{t_0})_{\#}V$ and hence, for k large enough, it is strictly smaller than the mass of V .

Therefore, if we fix a sufficiently large number k , we can assume that (iv) holds with a gain in mass of a positive amount $\varepsilon = 1/j$. We can, moreover, assume that $\mathcal{H}^2(\Delta^k) \leq \mathcal{H}^2(\Sigma) + 1/(8j)$. By an approximation procedure, it is possible to replace the family of projections $\{\pi_t\}_{t \in [0, t_0]}$ with a smooth isotopy $\{\psi_t\}_{t \in [0, 1]}$ with the following properties:

- (v) ψ_0 is the identity map and $\psi_t|_{\partial U}$ is the identity map for every $t \in [0, 1]$;
- (vi) $\mathcal{H}^2(\Delta^k) \leq \mathcal{H}^2(\psi_t(\Sigma)) + 1/(8j)$;
- (vii) $\mathcal{H}^2(\psi_1(\Delta^k)) \leq \mathbf{M}((\pi_{t_0})_{\#}V) - 1/j$.

This contradicts the $1/j$ -almost minimizing property of Σ .

In showing the existence of the family of isotopies ψ_t , a detail must be taken into account: the map π_t is smooth everywhere on \bar{U} but on the circle $f^{-1}(R_t) \cap \partial U$ (which is the same circle for every t !). We briefly indicate here a procedure to construct ψ_t , skipping the cumbersome details.

We replace the sets $\{R_t\}$ with a new family \mathcal{R}_t which have the following properties:

- $\mathcal{R}_0 = \bar{\mathcal{B}}_1$;
- $\mathcal{R}_{t_0} = R_{t_0}$;
- For $t \in [0, t_0]$ the boundaries $\partial\mathcal{R}_t$ are uniformly convex;
- $\partial\mathcal{R}_t \cap \partial\mathcal{B}_1 = R_t \cap \partial\mathcal{B}_1$;
- The boundaries of $\partial\mathcal{R}_t$ are smooth for $t \in [0, t_0[$ and form a smooth foliation of $\mathcal{B}_1(0) \setminus R_{t_0}$.

The properties of the new sets are illustrated in Figure 9

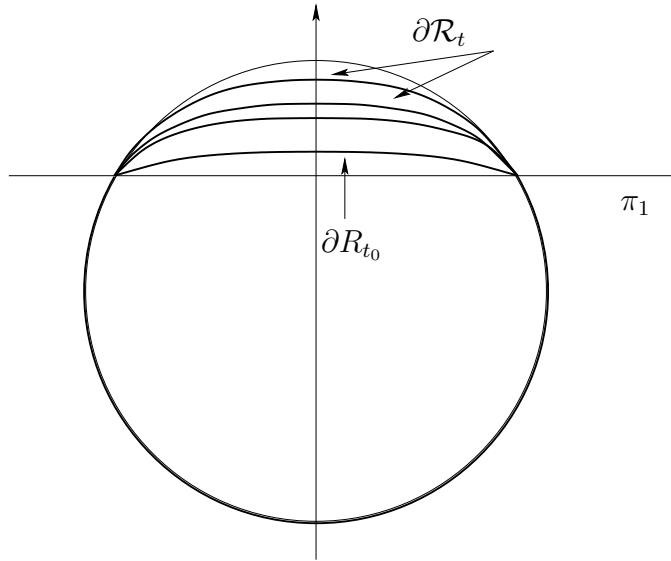

FIGURE 9. A planar cross-section of the new foliation.

Since $\overline{\Delta^k}$ touches ∂U in $\partial\Sigma$ transversally and $\partial\Sigma \subset f^{-1}(\mathcal{R}_t)$ for every t , we conclude the existence of a small δ such that $\Delta^k \subset f^{-1}(\mathcal{R}_{2\delta})$. Moreover, for δ sufficiently small, the nearest point projection $\tilde{\pi}_{t_0-\delta}$ on $f^{-1}(\mathcal{R}_{t_0-\delta})$ is so close to π_{t_0} that

$$\mathbf{M}((\tilde{\pi}_{t_0-\delta})_{\#}\Delta^k) \leq \mathbf{M}((\pi_{t_0})_{\#}\Delta^k) + \varepsilon/4.$$

We then construct ψ_t in the following way. We fix a smooth increasing bijective function $\tau : [0, 1] \rightarrow [\delta, t_0 - \delta]$,

- ψ_t is the identity on $\overline{U} \setminus \mathcal{R}_\delta$ and on $\mathcal{R}_{\tau(t)}$;
- On $\mathcal{R}_\delta \setminus \mathcal{R}_{\tau(t)}$ it is very close to the projection $\tilde{\pi}_{\tau(t)}$ on $\mathcal{R}_{\tau(t)}$.

In particular, for this last step, we fix for a smooth function $\sigma : [0, 1] \times [0, 1]$ such that, for each t , $\sigma(t, \cdot)$ is a smooth bijection between $[0, 1]$ and $[\delta, \tau(t)]$ very close to the function which is identically $\tau(t)$ on $[0, 1]$. Then, for $s \in [0, 1]$, we define ψ_t on the surface $\partial\mathcal{R}_{(1-s)\delta+s\tau(t)}$ to be the nearest point projection on the surface $\partial\mathcal{R}_{\sigma(t,s)}$. So, ψ_t fixes the leave $\partial\mathcal{R}_\delta$ but moves most of the leaves between $\partial\mathcal{R}_\delta$ and $\partial\mathcal{R}_{\tau(t)}$ towards $\partial\mathcal{R}_{\tau(t)}$. This completes the proof of Lemma 5.3.

6. PROOF OF PROPOSITION 3.2. PART II: SQUEEZING LEMMA

In this section we prove the following Lemma.

Lemma 6.1 (Squeezing Lemma). *Let $\{\Delta^k\}$ be as in Proposition 3.2, $x \in \overline{U}$ and $\beta > 0$ be given. Then there exists an $\varepsilon_0 > 0$ and a $K \in \mathbb{N}$ with the following property. If $k \geq K$ and $\varphi \in \mathfrak{Is}(B_{\varepsilon_0}(x) \cap U)$ is such that $\mathcal{H}^2(\varphi(1, \Delta^k)) \leq \mathcal{H}^2(\Delta^k)$, then there exists a $\Phi \in \mathfrak{Is}(B_{\varepsilon_0}(x) \cap U)$ such that*

$$\Phi(1, \cdot) = \varphi(1, \cdot) \tag{6.1}$$

$$\mathcal{H}^2(\Phi(t, \Delta^k)) \leq \mathcal{H}^2(\Delta^k) + \beta \quad \text{for every } t \in [0, 1]. \tag{6.2}$$

If x is an interior point of U , this lemma reduces to Lemma 7.6 of [8]. When x is on the boundary of U , one can argue in a similar way (cp. with Section 7.4 of [8]). Indeed, the proof of Lemma 7.6 of [8] relies on the fact that, when ε is sufficiently small, the varifold V is close to a cone. For interior points, this follows from the stationarity of the varifold V . For points at the boundary this, thanks to a result of Allard (see [3]), is a consequence of the stationarity of V and of the convex hull property of Lemma 5.3.

6.1. Tangent cones. Consider the varifold V of Proposition 3.2. Given a point $x \in \overline{U}$ and a radius $\rho > 0$, consider the chart $f_{x,\rho} : B_\rho(x) \rightarrow \mathcal{B}_1$ given by $f_{x,\rho}(y) = \exp_x^{-1}(y)/\rho$. We then consider the varifolds $V_{x,\rho} := (f_{x,\rho})_{\#}V$. Moreover, if $\lambda > 0$, we will denote by $O_\lambda : \mathbf{R}^3 \rightarrow \mathbf{R}^3$ the rescaling $O_\lambda(x) = x/\lambda$.

If $x \in U$, the monotonicity formula and a compactness result (see Theorem 19.3 of [18]) imply that, for any $\rho_j \downarrow 0$, there exists a subsequence, not relabeled, such that V_{x,ρ_j} converges to an integer rectifiable varifold W supported in \mathcal{B}_1 with the property that $(O_\lambda)_{\#}W \llcorner B_1(0) = W$ for any $\lambda < 1$. The varifolds W which are limit of subsequences V_{x,ρ_j} are called tangent cones to V at x . The monotonicity formula implies that the mass of each W is a positive constant $\theta(x, V)$ independent of W (see again Theorem 19.3 of [18]).

If $x \in \partial U$, we fix coordinates y_1, y_2, y_3 in \mathbf{R}^3 in such a way that $f_{x,\rho}(U \cap B_\rho(x))$ converges to the half-ball $\mathcal{B}_1^+ = \mathcal{B}_1 \cap \{y_1 > 0\}$.

Recalling Lemma 5.3, we can infer with the monotonicity formula of Allard for points at the boundary (see 3.4 of [3]) that $V_{x,\rho} = (f_{x,\rho})_{\#}V$ have equibounded mass. Therefore, if $\rho_j \downarrow 0$, a subsequence of V_{x,ρ_j} , not relabeled, converges to a varifold W .

By Lemma 5.3, there is a positive angle θ_0 such that, after a suitable change of coordinates, W is supported in the set

$$\{|y_2| \leq y_1 \tan \theta_0\}.$$

Therefore $\text{supp}(W) \cap \{y_1 = 0\} = \{(0, 0, t) : t \in [-1, 1]\} =: \ell$. Applying the monotonicity formula of 3.4 of [3], we conclude that

$$\|W\|(\ell) = 0 \tag{6.3}$$

and

$$\|W\|(\mathcal{B}_\rho(0)) = \pi\theta(\|V\|, x)\rho^2, \tag{6.4}$$

where

$$\theta(\|V\|, x) = \lim_{r \downarrow 0} \frac{\|V\|(B_r(x))}{\pi r^2}$$

is independent of W . Being W the limit of a sequence V_{x,ρ_j} with $\rho_j \downarrow 0$, we conclude that W is a stationary varifold.

Now, define the reflection map $r : \mathbf{R}^3 \rightarrow \mathbf{R}^3$ given by $r(z_1, z_2, z_3) = (-z_1, -z_2, z_3)$. By (6.3), using the reflection principle of 3.2 of [3], the varifold $W' := W + r_{\#}W$ is a stationary varifold. By (6.4) and Corollary 2 of 5.1 in [2], we conclude that $(O_\lambda)_{\#}W' \llcorner \mathcal{B}_1^+ = W'$ for every $\lambda < 1$. On the other hand, this implies $(O_\lambda)_{\#}W \llcorner \mathcal{B}_1^+ = W$. Therefore W is a cone and we will call it *tangent cone to V at x* .

6.2. A squeezing homotopy. Since for points in the interior the proof is already given in [8], we assume that $x \in \partial U$. Moreover, the proof given here in this case can easily be modified for $x \in U$. Therefore we next fix a small radius $\varepsilon > 0$ and consider an isotopy φ of $U \cap B_\varepsilon(x)$ keeping the boundary fixed.

We start by fixing a small parameter $\delta > 0$ which will be chosen at the end of the proof. Next, we consider a diffeomorphism G_ε between $\mathcal{B}_\varepsilon^+ = \mathcal{B}_\varepsilon \cap \{y_1 > 0\}$ and $B_\varepsilon(x) \cap U$. Consider on $\mathcal{B}_\varepsilon^+$ the standard Euclidean metric and denote the corresponding 2-dimensional Hausdorff measure with $\mathcal{H}_\varepsilon^2$. If ε is sufficiently small, then G_ε can be chosen so that the Lipschitz constants of G_ε and G_ε^{-1} are both smaller than $1 + \varepsilon$. Then, for any surface $\Delta \subset B_\varepsilon(x) \cap U$,

$$(1 - C\delta)\mathcal{H}^2(\Delta) \leq \mathcal{H}_\varepsilon^2(G_\varepsilon(\Delta)) \leq (1 + C\delta)\mathcal{H}^2(\Delta), \tag{6.5}$$

where C is a universal constant.

We want to construct an isotopy $\Lambda \in \mathcal{I}\mathfrak{s}(\mathcal{B}_\varepsilon^+)$ such that $\Lambda(1, \cdot) = G_\varepsilon \circ \varphi(1, G_\varepsilon^{-1}(\cdot))$ and (for k large enough)

$$\mathcal{H}_\varepsilon^2(\Lambda(t, G_\varepsilon(\Delta^k))) \leq \mathcal{H}_\varepsilon^2(G_\varepsilon(\Delta^k))(1 + C\delta) + C\delta \quad \text{for every } t \in [0, 1]. \tag{6.6}$$

After finding Λ , $\Phi(t, \cdot) = G_\varepsilon^{-1} \circ \Lambda(t, G_\varepsilon(\cdot))$ will be the desired map. Indeed Φ is an isotopy of $B_\varepsilon(x) \cap U$ which keeps a neighborhood of $B_\varepsilon(x) \cap U$ fixed. It is easily checked that $\Phi(1, \cdot) = \varphi(1, \cdot)$. Moreover, by (6.5) and (6.6), for k sufficiently large we have

$$\mathcal{H}^2(\Phi(t, \Delta^k)) \leq (1 + C\delta)\mathcal{H}^2(\Delta^k) + C\delta \quad \forall t \in [0, 1], \tag{6.7}$$

for some constant C independent of δ and k . Since $\mathcal{H}^2(\Delta^k)$ is bounded by a constant independent of δ and k , by choosing δ sufficiently small, we reach the claim of the Lemma.

Next, we consider on $\mathcal{B}_\varepsilon^+$ a one-parameter family of diffeomorphisms. First of all we consider the continuous piecewise linear map $\alpha : [0, 1[\rightarrow [0, 1]$ defined in the following way:

- $\alpha(t, s) = s$ for $(t + 1)/2 \leq s \leq 1$;
- $\alpha(t, s) = (1 - t)s$ for $0 \leq s \leq t$;
- $\alpha(t, s)$ is linear on $t \leq s \leq (t + 1)/2$.

So, each $\alpha(t, \cdot)$ is a biLipschitz homeomorphism of $[0, 1]$ keeping a neighborhood of 1 fixed, shrinking a portion of $[0, 1]$ and uniformly stretching the rest. For t very close to 1, a large portion of $[0, 1]$ is shrunk into a very small neighborhood of 0, whereas a small portion lying close to 1 is stretched to almost the whole interval.

Next, for any given $t \in [0, 1[$, let $y_t := ((1 - t)\eta\varepsilon, 0, 0)$ where η is a small parameter which will be fixed later. For any $z \in \mathcal{B}_\varepsilon^+$ we consider the point $\pi_t(z) \in \partial\mathcal{B}_\varepsilon^+$ such that the segment $[y_t, \pi_t(z)]$ containing z . We then define $\Psi(t, z)$ to be the point on the segment $[y_t, \pi_t(z)]$ such that

$$|y_t - \Psi(t, z)| = \alpha\left(t, \frac{|y_t - z|}{|x_t - \pi_t(x)|}\right) |y_t - \pi_t(z)|.$$

It turns out that $\Psi(0, \cdot)$ is the identity map and, for fixed t , $\Psi(t, \cdot)$ is a biLipschitz homeomorphism of $\mathcal{B}_\varepsilon^+$ keeping a neighborhood of $\partial\mathcal{B}_\varepsilon^+$ fixed. Moreover, for t close to 1, $\Psi(t, \cdot)$ shrinks a large portion of $\mathcal{B}_\varepsilon^+$ in a neighborhood of y_t and stretches uniformly a layer close to $\partial\mathcal{B}_\varepsilon$. See Figure 10.

We next consider the isotopy $\Xi(t, \cdot) := G_\varepsilon^{-1} \circ \Psi(t, G_\varepsilon(\cdot))$. It is easy to check that, if we fix a Δ^k and we let $t \uparrow 1$, then the surfaces $\Psi(1, G_\varepsilon(\Delta^k))$ converge to the cone with center 0 and base $G_\varepsilon(\Delta^k) \cap \partial\mathcal{B}_\varepsilon$.

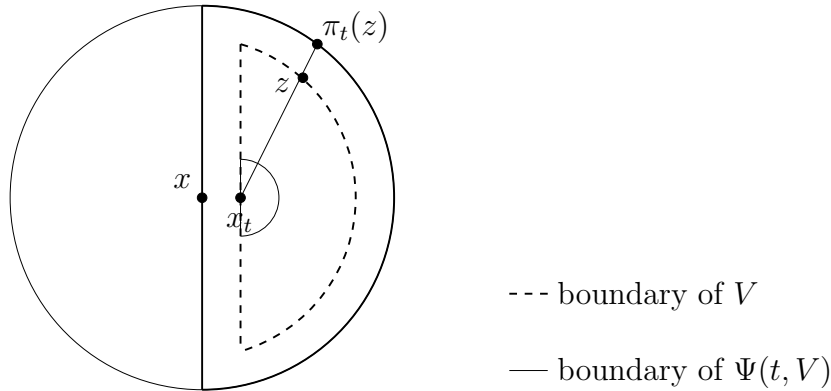

FIGURE 10. For t close to 1 the map $\Psi(t, \cdot)$ shrinks homotetically a large portion of $\mathcal{B}_\varepsilon^+$.

6.3. Fixing a tangent cone. By Subsection 6.1, we can find a sequence $\rho_l \downarrow 0$ such that V_{x, ρ_l} converges to a tangent cone W . Our choice of the diffeomorphism G_{ρ_l} implies that $(O_{\rho_l} \circ G_{\rho_l})_\# V$ has the same varifold limit as V_{x, ρ_l} .

Since Δ^k converges to V in the sense of varifolds, by a standard diagonal argument, we can find an increasing sequence of integers K_l such that:

- (C) $(O_{\rho_l}(G_{\rho_l}(\Delta^{k_l})))$ converges in the varifold sense to W , whenever $k_l \geq K_l$.

(C), the conical property of W and the coarea formula imply the following fact. For ρ_l sufficiently small, and for k sufficiently large, there is an $\varepsilon \in]\rho_l/2, \rho_l[$ such that:

$$\mathcal{H}_e^2(\Psi(t, G_\varepsilon(\Delta^k) \cap L)) \leq \mathcal{H}_e^2(G_\varepsilon(\Delta^k) \cap L) + \delta \quad \forall t \text{ and all open } L \subset \mathcal{B}_\varepsilon^+, \quad (6.8)$$

where Ψ is the map constructed in the previous subsection. This estimate holds independently of the small parameter η . Moreover, it fixes the choice of ε_0 and K as in the statement of the Lemma. K depends only on the parameter δ , which will be fixed later. ε might depend on $k \geq K$, but it is always larger than some fixed ρ_l , which will then be the ε_0 of the statement of the Lemma.

6.4. Construction of Λ . Consider next the isotopy $\psi = G_\varepsilon \circ \varphi \circ G_\varepsilon^{-1}$. By definition, there exists a compact set K such that $\psi(t, z) = z$ for $z \in \mathcal{B}_\varepsilon^+ \setminus K$ and every t . We now choose η so small that $K \subset \{x : x_1 > \eta\varepsilon\}$. Finally, consider $T \in]0, 1[$ with T sufficiently close to 1. We build the isotopy Λ in the following way:

- for $t \in [0, 1/3]$ we set $\Lambda(t, \cdot) = \Psi(3tT, \cdot)$;
- for $t \in [1/3, 2/3]$ we set $\Lambda(t, \cdot) = \Psi(3tT, \psi(3t - 1, \cdot))$;
- for $t \in [2/3, 1]$ we set $\Lambda(t, \cdot) = \Psi(3(1 - t)T, \psi(1, \cdot))$.

If T is sufficiently large, then Λ satisfies (6.6). Indeed, for $t \in [0, 1/3]$, (6.6) follows from (6.8). Next, consider $t \in [1/3, 2/3]$. Since $\psi(t, \cdot)$ moves only points of K , $\Lambda(t, x)$ coincides with $\Psi(T, x)$ except for x in $\Psi(T, K)$. However, $\Psi(T, x)$ is homotetic to K with a very small shrinking factor. Therefore, if T is chosen sufficiently large, $\mathcal{H}_e^2(\Lambda(t, G_\varepsilon(\Delta^k)))$ is arbitrarily close to $\mathcal{H}_e^2(\Lambda(1/3, G_\varepsilon(\Delta^k)))$. Finally, for $t \in [2/3, 1]$, $\Lambda(t, x) = \Psi(3(1 - t)T, x)$ for $x \notin \Psi(3(1 - t)T, K)$ and it is $\Psi(3(1 - t)T, \psi(1, x))$ otherwise. Therefore, $\Lambda(t, G_\varepsilon(\Delta^k))$ differs from $\Psi(3(1 - t)T, G_\varepsilon(\Delta^k))$ for a portion which is a rescaled version of $G_\varepsilon(\varphi(1, \Delta^k) \setminus G_\varepsilon(\Delta^k))$. Since by hypothesis $\mathcal{H}^2(\varphi(1, \Delta^k)) \leq \mathcal{H}^2(\Delta^k)$, we actually get

$$\mathcal{H}_e^2(G_\varepsilon(\varphi(1, \Delta^k)) \setminus G_\varepsilon(\Delta^k)) \leq (1 + C\delta)\mathcal{H}_e^2(G_\varepsilon(\Delta^k) \setminus G_\varepsilon(\varphi(1, \Delta^k)))$$

and by the scaling properties of the euclidean Hausdorff measure we conclude (6.6) for $t \in [2/3, 1]$ as well.

Though Λ is only a path of biLipschitz homeomorphisms, it is easy to approximate it with a smooth isotopy: it suffices indeed to smooth $\alpha|_{[0, T] \times [0, 1]}$, for instance mollifying it with a standard kernel.

7. PROOF OF PROPOSITION 3.2. PART III: γ -REDUCTION

In this section we prove the following

Lemma 7.1 (Interior regularity). *Let V be as in Proposition 3.2. Then $\|V\| = \mathcal{H}^2 \llcorner \Delta$ where Δ is a smooth stable minimal surface in U (multiplicity is allowed).*

In fact the lemma follows from the interior version of the squeezing lemma and the following proposition, applying the regularity theory of replacements as described in [8] (cp. with Section 7 therein).

Proposition 7.2. *Let U be an open ball with sufficiently small radius. If Λ is an embedded surface with smooth boundary $\partial\Lambda \subset \partial U$ and $\{\Lambda^k\}$ is a minimizing sequence for Problem $(\Lambda, \mathfrak{I}\mathfrak{s}(U))$ converging to a varifold W , then there exists a stable minimal surface Γ with $\bar{\Gamma} \setminus \Gamma \subset \partial\Lambda$ and $W = \Gamma$ in U .*

This Proposition has been claimed in [8] (cp. with Theorem 7.3 therein) and since nothing on the behavior of W at the boundary is claimed, it follows from a straightforward modification of the theory of γ -reduction of [13] (as asserted in [8]). This simple modification of the γ -reduction is, as the original γ -reduction, a procedure to reduce through simple surgeries the minimizing sequence Λ^k into a more suitable sequence.

In this section we also wish to explain why this argument cannot be directly applied neither to the surfaces Δ^k of Proposition 3.2 on the *whole* domain U (see Remark 7.6), nor to their intersections with a smaller set U' (see Remark 7.7). In the first case, the obstruction comes from the $1/j$ -a.m. property, which is not powerful enough to perform certain surgeries. In the second case this obstruction could be removed by using the squeezing lemma, but an extra difficulty pops out: the intersection $\Delta^k \cap \partial U'$ is, this time, not fixed and the topology of $\Delta^k \cap U'$ is not controlled. These technical problems are responsible for most of the complications in our proof.

7.1. Definition of the γ -reduction. In what follows, we assume that an open set $U \subset M$ and a surface Λ in M with $\partial\Lambda \subset \partial U$ are fixed. Moreover, we let \mathcal{C} denote the collection of all compact smooth 2-dimensional surfaces embedded in U with boundary equal to $\partial\Lambda$.

We next fix a positive number δ such that the conclusion of Lemma 1 in [13] holds and consider $\gamma < \delta^2/9$. Following [13] we define the γ -reduction and the strong γ -reduction.

Definition 7.3. For $\Sigma_1, \Sigma_2 \in \mathcal{C}$ we write

$$\Sigma_2 \stackrel{(\gamma, U)}{\ll} \Sigma_1$$

and we say that Σ_2 is a (γ, U) -reduction of Σ_1 , if the following conditions are satisfied:

- (γ 1) Σ_2 is obtained from Σ_1 through a surgery as described in Definition 2.2. Therefore:
 - $\overline{\Sigma_1 \setminus \Sigma_2} = A \subset U$ is diffeomorphic to the standard closed annulus $\overline{\text{An}(x, 1/2, 1)}$;
 - $\Sigma_2 \setminus \Sigma_1 = D_1 \cup D_2 \subset U$ with each D_i diffeomorphic to \mathcal{D} ;
 - There exists a set Y embedded in U , homeomorphic to \mathcal{B}_1 with $\partial Y = A \cup D_1 \cup D_2$ and $(Y \setminus \partial Y) \cap (\Sigma_1 \cup \Sigma_2) = \emptyset$. (See Picture 2).
- (γ 2) $\mathcal{H}^2(A) + \mathcal{H}^2(D_1) + \mathcal{H}^2(D_2) < 2\gamma$;
- (γ 3) If Γ is the connected component of $\Sigma_1 \cup \overline{U}$ containing A , then for each component of $\Gamma \setminus A$ we have one of the following possibilities:
 - either it is a disc of area $\geq \delta^2/2$;
 - or it is not simply connected.

Remark 7.4. The previous definition has another interesting consequence that the reader could easily check: $\Sigma \in \mathcal{C}$ is (γ, U) -irreducible if and only if whenever Δ is a disc with $\partial\Delta = \Delta \cap \Sigma$ and $\mathcal{H}^2(\Delta) < \gamma$, then there is a disc $D \subset \Sigma$ with $\partial D = \partial\Delta$ and $\mathcal{H}^2(D) < \delta^2/2$.

A slightly weaker relation than $\stackrel{(\gamma, U)}{\ll}$ can be defined as follows. We consider $\Sigma_1, \Sigma_2 \in \mathcal{C}$ and we say that Σ_2 is a strong (γ, U) -reduction of Σ_1 , written $\Sigma_2 \stackrel{(\gamma, U)}{<} \Sigma_1$, if there exists an isotopy $\psi \in \mathfrak{Is}(U)$ such that

- (s1) $\Sigma_2 \stackrel{(\gamma, U)}{\ll} \psi(\Sigma_1)$;
- (s2) $\Sigma_2 \cap (M \setminus U) = \Sigma_1 \cap (M \setminus U)$;
- (s3) $\mathcal{H}^2(\psi(\Sigma_1) \Delta \Sigma_1) < \gamma$.

We say that $\Sigma \in \mathcal{C}$ is strongly (γ, U) -irreducible if there is no $\tilde{\Sigma} \in \mathcal{C}$ such that $\tilde{\Sigma} \stackrel{(\gamma, U)}{<} \Sigma$.

Remark 7.5. *Arguing as in [13] one can prove that, for every $\Lambda' \in \mathcal{C}$, there exist a constant $c \geq 1$ (depending on δ , $\mathbf{g}(\Lambda')$ and $\mathcal{H}^2(\Lambda')$) and a sequence of surfaces Σ_j , $j = 1, \dots, k$, such that*

$$k \leq c; \tag{7.1}$$

$$\Sigma_j \in \mathcal{C}; \quad j = 1, \dots, k; \tag{7.2}$$

$$\Sigma_k \stackrel{(\gamma, U)}{<} \Sigma_{k-1} \stackrel{(\gamma, U)}{<} \dots \stackrel{(\gamma, U)}{<} \Sigma_1 = \Lambda'; \tag{7.3}$$

$$\mathcal{H}^2(\Sigma_k \Delta \Lambda') \leq 3c\gamma; \tag{7.4}$$

$$\Sigma_k \text{ is strongly } (\gamma, U)\text{-irreducible.} \tag{7.5}$$

Compare with Section 3 of [13] and in particular with (3.3), (3.4), (3.8) and (3.9) therein.

7.2. Proof of Proposition 7.2. Applying Lemma 5.3, we conclude that a subsequence, not relabeled, of Λ^k converges to a stationary varifold V in \bar{U} such that $\bar{U} \cap \text{supp}(V) \subset \partial\Lambda$. Next, arguing as in Section 6.1, we conclude that $\|V\|(\partial\Lambda) = 0$, and hence that $\|V\|(\partial U) = 0$. Arguing as in pages 364-365 of [13] (see (3.22)–(3.26) therein), we find a $\gamma_0 > 0$ and a sequence of γ_0 -strongly irreducible surfaces Σ^k with the following properties:

- Σ^k is obtained from Λ^k through a number of surgeries which can be bounded independently of k ;
- Σ^k converges, in the sense of varifolds, to V .

This allows to apply Theorem 2 and Section 5 of [13] to the surfaces Σ^k to conclude that $\text{supp}(V) \setminus \partial U$ is a smooth embedded stable minimal surface.

Remark 7.6. *This procedure cannot be applied if the minimality of the sequence Λ^k in $\mathfrak{Is}(U)$ were replaced by the minimality in $\mathfrak{Is}_j(U)$. In fact, the proof of Theorem 2 in [13] uses heavily the minimality in $\mathfrak{Is}(U)$ and we do not know how to overcome this issue.*

7.3. Proof of Lemma 7.1. Let Δ^k and V be as in Proposition 3.2 and in Lemma 7.1. Let $x \in U$ and consider a $U' = B_\varepsilon(x) \subset U$ as in Lemma 6.1. Applying Lemma 6.1 we can modify Δ^k in $B_\varepsilon(x)$ getting a minimizing sequence $\{\Delta^{k,j}\}_j$ for $\mathfrak{Is}(B_\varepsilon(x))$. Applying Proposition 7.2, we can assume that $\Delta^{k,j}$ converges, as $j \uparrow \infty$ to a varifold V'_k which in $B_\varepsilon(x)$ is a stable minimal surface Σ^k . By the curvature estimates for minimal surfaces (cp. also with the Choi-Schoen compactness Theorem), we can assume that Σ^k converges to a stable smooth minimal surface Σ^∞ . Extracting a diagonal subsequence $\tilde{\Delta}^k := \Delta^{k,j(k)}$, we can assume that $\tilde{\Delta}^k$ is still minimizing for problem $\mathfrak{Is}_j(U)$ and hence that it converges to a varifold V' . V' coincides with Σ in $B_\varepsilon(x)$ and with V outside $B_\varepsilon(x)$ and hence it is a replacement according to Definition 6.2 in [8] (see Section 7 therein). By Proposition 6.3 of [8], V coincides with a smooth embedded minimal surface in U .

Remark 7.7. *Note that the arguments of Section 3 of [13] cannot be applied directly to the sequence Δ^k . It is indeed possible to modify Δ^k in $B_\varepsilon(x) =: U'$ to a strongly γ -irreducible $\tilde{\Delta}^k$. However, the number of surgeries needed is controlled by $\mathcal{H}^2(\Delta^k \cap B_\varepsilon(x))$ and $\mathbf{g}(\Delta^k \cap U')$. Though the first quantity can be bounded independently of k , on the second quantity (i.e. $\mathbf{g}(\Delta^k \cap U')$) we do not have any a priori uniform bound.*

8. PROOF OF PROPOSITION 3.2. PART IV: BOUNDARY REGULARITY.

In this section we conclude the proof of the first part of Propositions 3.2 and 3.3. More precisely, we show that the surface Δ of Lemma 7.1 is regular up to the boundary and its boundary coincides with $\partial\Sigma$.

Lemma 8.1 (Boundary regularity). *Let Δ be as in Lemma 7.1. Then Δ has a smooth boundary and $\partial\Delta = \partial\Sigma$.*

As a corollary, we conclude that the multiplicity of Δ is everywhere 1.

Corollary 8.2. *There exist finitely many stable embedded connected disjoint minimal surfaces $\Gamma_1, \dots, \Gamma_N \subset U$ with disjoint smooth boundaries and with multiplicity 1 such that*

$$\Delta = \Gamma_1 \cup \dots \cup \Gamma_N \quad \text{and} \quad \partial\Delta = \partial\Gamma_1 \cup \dots \cup \partial\Gamma_N. \quad (8.1)$$

Proof. Lemmas 7.1 and 8.1 imply that Δ is the union of finitely many disjoint connected components $\Gamma_1 \cup \dots \cup \Gamma_N$ contained in U and that either $\partial\Gamma_i = 0$ or $\partial\Gamma_i$ is the union of some connected components of $\partial\Sigma$. In this last case, the multiplicity of Γ_i is necessarily 1. On the other hand, $\partial\Gamma_i = 0$ cannot occur, otherwise Γ_i would be a smooth embedded minimal surface without boundary contained in a convex ball of a Riemannian manifold, contradicting the classical maximum principle. \square

8.1. Tangent cones at the boundary. Consider now $x \in \text{supp } \|V\| \cap \partial U$. We follow Subsection 6.1 and consider the chart $f_{x,\rho} : B_\rho(x) \rightarrow \mathcal{B}_1$ given by $f_{x,\rho}(y) = \exp_x^{-1}(y)/\rho$. We then denote by $V_{x,\rho}$ the varifolds $(f_{x,\rho})_\# V$. Moreover, if $\lambda > 0$, we will denote by $O_\lambda : \mathbf{R}^3 \rightarrow \mathbf{R}^3$ the rescaling $O_\lambda(x) = x/\lambda$.

Let next W be the limit of a subsequence V_{x,ρ_j} . Again following the discussion of Subsection 6.1, we can choose a system of coordinates (y_1, y_2, y_3) such that:

- W is integer rectifiable and $\text{supp } (W)$ is contained in the wedge

$$\text{Wed} := \{(y_1, y_2, y_3) : |y_2| \leq y_1 \tan \theta_0\} \cap \overline{\mathcal{B}}_1(0).$$

- $\text{supp } (W)$ contains the line $\ell = \{(0, 0, t) : t \in [-1, 1]\}$, (which is the limit of the curves $f_{x,\rho}(\partial\Sigma \cap B_\rho(x))$).
- If we denote by $r : \mathbf{R}^3 \rightarrow \mathbf{R}^3$ the reflection given by $r(z_1, z_2, z_3) = (-z_1, -z_2, z_3)$, then $r_\# W + W$ is a stationary cone.

By the Boundary regularity Theorem of Allard (see Section 4 of [3]), in order to show regularity it suffices to prove that

(TC) Any W as above (i.e. any varifold limit of a subsequence $(f_x^{\rho_n})_\# V$ with $\rho_n \downarrow 0$) is a half-disk of the form

$$P_\theta := \{(y_1, y_2, y_3) : y_1 > 0, y_3 = y_1 \tan \theta\} \cap \mathcal{B}_1(0) \quad (8.2)$$

for some angle $\theta \in]-\pi/2, \pi/2[$.

In the rest of this section we aim, therefore, at proving (TC). As a first step we now show that

$$W = \sum_{i=1}^N k_i P_{\theta_i} \quad (8.3)$$

where $k_i \geq 1$ are integers and θ_i are angles in $[-\theta_0, \theta_0]$. There are two possible ways of seeing this. One way is to use the Classification of stationary integral varifolds proved by Allard and Almgren in [1].

The second, which is perhaps simpler, is to observe that, on \mathcal{B}^+ the varifold W is actually smooth. Indeed, by the interior regularity, V is a smooth minimal surface in $B_\rho(x) \cap V$ and it is stable, therefore, by Schoen's curvature estimates, a subsequence of V_{x, ρ_n} converges smoothly in compact subsets of \mathcal{B}^+ . It follows that $W^r := W + r_\# W$ coincides with a smooth minimal surface outside on $\mathcal{B}_1(0) \setminus \ell$. On the other hand W^r is a cone and therefore we conclude that $\partial \mathcal{B}_{1/2}(0) \cap W^r \setminus \{(0, 0, 1/2), (0, 0, -1/2)\}$ is a smooth 1-d manifold consisting of arcs of great circles. Since $\text{supp}(W) \subset \text{Wed}$, we conclude that in fact $\partial \mathcal{B}_{1/2}(0) \cap W^r \setminus \{(0, 0, 1/2), (0, 0, -1/2)\}$ consists of finitely many planes (multiplicity is allowed) passing through ℓ . This proves (8.3).

8.2. Diagonal sequence. We are now left with the task of showing that $N = 1$ and $k_1 = 1$. We will, indeed, assume the contrary and derive a contradiction. In order to do so, we consider a suitable diagonal sequence $f_{x, \rho_n}(\Delta^{k_n})$ converging, in the sense of varifolds, to W . We can select Δ^{k_n} in such a way that the following minimality property holds:

(F) If Λ is any surface isotopic to Δ^{k_n} with an isotopy fixing $\partial(U \cap B_{\rho_n}(x))$, then $\mathcal{H}^2(\Lambda) \geq \mathcal{H}^2(\Delta^{k_n}) - \rho_n^3$.

Indeed, we apply the Squeezing Lemma 6.1 with $\beta = 1/(16j)$ and let n be so large that ρ_n is smaller than the constant ε_0 given by the Lemma. Since Δ^k is $1/j$ -a.m. in U , we conclude therefore that, if we set

$$M_{k,n} := \inf\{\Phi(1, \Delta^k) : \Phi \in \mathfrak{I}\mathfrak{s}(U \cap B_{\rho_n}(x))\},$$

then

$$\lim_{k \uparrow \infty} \mathcal{H}^2(\Delta^k \cap B_{\rho_n}(x)) - M_{n,k} = 0.$$

Therefore, having fixed $\rho_n < \varepsilon_0$, we can choose k_n so large that $M_{n,k} \geq \mathcal{H}^2(\Delta^{k_n}) - \rho_n^3$.

Next, it is convenient to introduce a slightly perturbed chart $g_x^{\rho_n}$ which maps $\partial U \cap B_{\rho_n}(x)$ onto $\mathcal{B}_1 \cap \{y_1 = 0\}$ and $\partial \Sigma \cap B_{\rho_n}(x)$ onto ℓ . This can be done in such a way that $f_{x, \rho_n} \circ g_x^{\rho_n}$ and $g_{x, \rho_n} \circ f_{x, \rho_n}^{-1}$ converge smoothly to the identity map as $\rho_n \downarrow 0$.

Having set $\Gamma_n = g_{x, \rho_n}(\Delta^{k_n})$, we have that Γ_n converges to W in the sense of varifolds. Moreover, our discussion implies that $\mathcal{H}^2(\Delta^{k_n} \cap B_{\rho_n}(x)) = \rho_n^2 \mathcal{H}_e^2(\Gamma_n) + O(\rho_n^3)$. Therefore we conclude from (F) that

(F') Let m_n be the minimum of $\mathcal{H}_e^2(\Lambda)$ over all surfaces Λ isotopic to Γ_n with an isotopy which fixes $\partial(U \cap \mathcal{B}_1)$. Then $\mathcal{H}_e^2(\Gamma_n) - m_n \downarrow 0$.

We next claim that

$$\liminf_{n \downarrow 0} \mathcal{H}_e^1(\Gamma_n \cap \partial \mathcal{B}_\sigma) \geq \pi \sigma \sum_{i=1}^N k_i \quad \text{for every } \sigma \in]0, 1[. \quad (8.4)$$

Indeed, using the squeezing homotopies of Section 6.2 it is easy to see that

$$\mathcal{H}_e^2(\Gamma_n) - m_n \geq \mathcal{H}_e^2(\Gamma_n \cap \mathcal{B}_\sigma) - \sigma \mathcal{H}_e^1(\Gamma_n \cap \partial \mathcal{B}_\sigma)$$

Letting $n \uparrow 0$ and using (8.3) with the convergence of Γ_n to the varifold W we conclude

$$\liminf_{n \uparrow \infty} (\mathcal{H}_e^2(\Gamma_n) - m_n) \geq \sigma \left(\sigma \pi \sum_i k_i - \liminf_{n \downarrow 0} \mathcal{H}_e^1(\Gamma_n \cap \partial \mathcal{B}_\sigma) \right).$$

Therefore, from (F') we conclude (8.4).

We next claim the existence of a $\sigma \in [1/2, 1[$ and a subsequence $n(j)$ such that $\Gamma_{n(j)} \cap \partial \mathcal{B}_\sigma$ is a smooth 1-dimensional manifold with boundary $(0, 0, \sigma) - (0, 0, -\sigma)$ and, at the same time,

$$\lim_{j \uparrow \infty} \mathcal{H}_e^1(\Gamma_{n(j)} \cap \partial \mathcal{B}_\sigma) = \pi \sigma \sum_{i=1}^N k_i \quad (8.5)$$

and

$$\lim_{j \uparrow \infty} \mathcal{H}_e^1(\Gamma_{n(j)} \cap \partial \mathcal{B}_\sigma \setminus K) = 0 \quad \text{for every compact } K \subset \mathcal{B}_1 \setminus \bigcup_i P_{\theta_i}. \quad (8.6)$$

In fact, let $\{K_l\}_l$ be an exhaustion of $\mathcal{B}_1 \setminus \bigcup_i P_{\theta_i}$ by compact sets. Observe that, by the convergence of Γ_n to W , we get

$$\lim_{n \uparrow \infty} \left(\mathcal{H}_e^2(\Gamma_n \cap \mathcal{B}_1 \setminus \mathcal{B}_{1/2}) + \sum_{l=0}^{\infty} 2^{-l} \mathcal{H}_e^2(\Gamma_n \setminus K_l \cap (\mathcal{B}_1 \setminus \mathcal{B}_{1/2})) \right) = \frac{\pi}{8} \sum_i k_i. \quad (8.7)$$

Using the coarea formula, we conclude

$$\int_{1/2}^1 \sigma \pi \sum_i k_i d\sigma \geq \lim_{n \uparrow \infty} \int_{1/2}^1 \left(\mathcal{H}_e^1(\Gamma_n \cap \partial \mathcal{B}_\sigma) + \sum_l 2^{-l} \mathcal{H}_e^1(\Gamma_n \cap \partial \mathcal{B}_\sigma \setminus K_l) \right) d\sigma.$$

Therefore, by Fatou's Lemma, for a.e. $\sigma \in [1/2, 1[$ there is a subsequence $n(j)$ such that

$$\lim_{j \uparrow \infty} \left(\mathcal{H}_e^1(\Gamma_n \cap \partial \mathcal{B}_\sigma) + \sum_l 2^{-l} \mathcal{H}_e^1(\Gamma_n \cap \partial \mathcal{B}_\sigma \setminus K_l) \right) = \pi \sigma \sum_i k_i. \quad (8.8)$$

Clearly, (8.4) and (8.8) imply (8.5) and (8.6). On the other hand, by Sard's Theorem, for a.e. $\sigma \in [1/2, 1[$ every surface $\partial \mathcal{B}_\sigma \cap \Gamma_n$ is a smooth 1-dimensional submanifold with boundary $(0, 0, \sigma) - (0, 0, -\sigma)$.

8.3. Disks. From now on we fix the radius σ found above and we use Γ_n in place of $\Gamma_{n(i)}$ (i.e. we do not relabel the subsequence). Consider now the Jordan curves $\gamma_1^n, \dots, \gamma_{M(n)}^n$ forming $\Gamma^n \cap \partial \mathcal{B}_\sigma^+$ (by \mathcal{B}_σ^+ we understand the half ball $\mathcal{B}_\sigma \cap \{y_1 \geq 0\}$).

Since $\partial \Gamma^n \cap \{y_1 = 0\}$ is given by the segment ℓ , there is one curve, say γ_1^n , which contains the segment ℓ . All the others, i.e. the curves γ_i^n with $i \geq 2$ lie in $\partial \mathcal{B}_\sigma \cap \{y_1 > 0\}$.

Next, for every γ_i^n consider the number

$$\kappa_i^n := \inf \{ \mathcal{H}_e^2(D) : D \text{ is an embedded smooth disk bounding } \gamma_i^n \}. \quad (8.9)$$

We will split our proof into several steps.

- (a) In the first step, we combine a simple desingularization procedure with the fundamental result of Almgren and Simon (see [4]), to show that

there are disjoint embedded smooth disks $D_1^n, \dots, D_{M(n)}^n$ s.t.

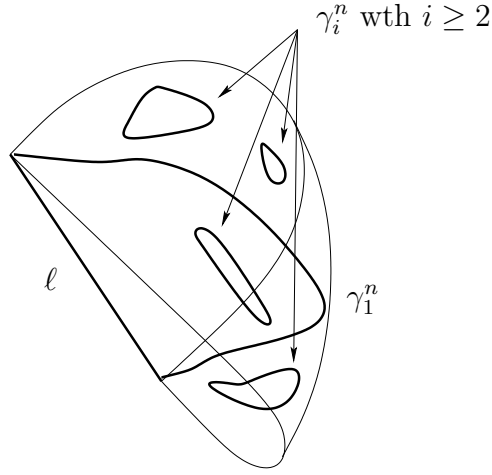
FIGURE 11. The curves γ_i^n .

$$\sum_{i=1}^{M(n)} \mathcal{H}_e^2(D_i^n) \leq \sum_{i=1}^{M(n)} \kappa_i^n + \frac{1}{n}. \quad (8.10)$$

A simple topological observation (see Lemma C.1 in the Appendix C) shows that, for each fixed n , there exist isotopies Φ_l keeping $\partial\mathcal{B}_\sigma^+$ fixed and such that $\Phi_l(\Gamma_n \cap \mathcal{B}_\sigma)$ converges, in the sense of varifolds, to the union of the disks D_i^n . Combining (F'), (8.10) and the convergence of Γ_n to the varifold W we then conclude

$$\limsup_{n \uparrow \infty} \sum_{i=1}^{M(n)} \kappa_i^n = \pi\sigma^2 \sum_j k_j. \quad (8.11)$$

(b) In the second step we will show the existence of a $\delta > 0$ (independent of n) such that

$$\kappa_i^n \leq \sigma \left(\frac{1}{2} - \delta \right) \mathcal{H}_e^1(\gamma_i^n) \quad \text{for every } i \geq 2 \text{ and every } n. \quad (8.12)$$

A simple cone construction shows that

$$\kappa_1^n \leq \frac{\sigma}{2} \mathcal{H}_e^1(\gamma_1^n). \quad (8.13)$$

So, (8.5), (8.12) and (8.13) imply

$$\lim_{n \uparrow \infty} \sum_{i=2}^{M(n)} \mathcal{H}_e^1(\gamma_i^n) = 0 \quad \text{and} \quad \lim_{n \uparrow \infty} \mathcal{H}_e^1(\gamma_1^n) = \sigma \sum_j k_j, \quad (8.14)$$

which in turn give

$$\lim_{n \uparrow \infty} \kappa_1^n = \frac{\pi\sigma^2}{2} \sum_j k_j. \quad (8.15)$$

(c) We next fix a parameterization $\beta_1^n : \mathbf{S}^1 \rightarrow \partial\mathcal{B}_\sigma^+$ of γ_1^n with a multiple of the arc-length and extract a further subsequence, not relabeled such that β_1^n converges to a β^∞ . By

(8.6), the image of β^∞ is then contained in the union of the curves $P_{\theta_i} \cap \partial\mathcal{B}_\sigma^+$. We will then show that

$$\limsup_{n \downarrow \infty} \kappa_1^n = \frac{\pi\sigma^2}{2}. \quad (8.16)$$

(8.15) and (8.16) finally show that W consists of a single half-disk $P_\theta \cap \mathcal{B}_1^+$, counted once. This will therefore complete the proof.

8.4. Proof of (8.10). In this step we fix n and prove the claim (8.10). First of all, note that each γ_i^n with $i \geq 2$ is a smooth Jordan curve lying in $\partial B_\sigma \cap \{y_1 > 0\}$.

We recall the following result of Almgren and Simon (see [4]).

Theorem 8.3. *For every curve γ_i^n with $i \geq 2$ consider a sequence of smooth disks D^j with $\mathcal{H}_e^2(D^j)$ converging to κ_i^n . Then a subsequence, not relabeled, converges, in the sense of varifolds, to an embedded smooth disk $D_i^n \subset \mathcal{B}_\sigma^+$ bounding γ_i^n and such that $\mathcal{H}_e^2(D_i^n) = \kappa_i^n$. (The disk is smooth also at the boundary).*

For each γ_i^n select therefore a disk D_i^n as in Theorem 8.3. We next claim that these disks are all pairwise disjoint. Fix in fact two such disks. To simplify the notation we call them D^1 and D^2 and assume they bound, respectively, the curves γ_1 and γ_2 . Clearly, D^1 divides \mathcal{B}_σ^+ into two connected components A and B and γ_2 lies in one of them, say A . We will show that D^2 lies in A .

Assume by contradiction that D^2 intersects D^1 . By perturbing D^2 a little we modify it to a new disk E^j such that $\mathcal{H}_e^2(E^j) \leq \mathcal{H}_e^2(D^2) + 1/j$ and E^j intersects D^1 transversally in finitely many smooth Jordan curves α_m .

Each α_m bounds a disk F^m in E^j . We call α_m maximal if it is not contained in any F^l . Each maximal α_m bounds also a disk G^m in D^1 . By the minimality of D^1 , clearly $\mathcal{H}_e^2(G^m) \leq \mathcal{H}_e^2(F^m)$. We therefore consider the new disk H^j given by

$$D^2 \setminus \left(\bigcup_{\alpha_m \text{ maximal}} F^m \right) \cup \bigcup_{\alpha_m \text{ maximal}} G^m.$$

Clearly $\mathcal{H}_e^2(H^j) \leq \mathcal{H}_e^2(E^j) + 1/j$. With a small perturbation we find a nearby smooth embedded disk K^j which lies in A and has $\mathcal{H}_e^2(K^j) \leq \mathcal{H}_e^2(E^j) + 1/(2j)$. By letting $j \uparrow \infty$ and applying Theorem 8.3, a subsequence of K^j converges to a smooth embedded minimal disk D^3 in the sense of varifolds. On the other hand, by choosing K^j sufficiently close to H^j , we conclude that H^j converges as well to the same varifold. But then,

$$D^2 \setminus \left(\bigcup_{\alpha_m \text{ maximal}} F^m \right) \subset D^3$$

and hence $D^2 \cap D^3 \neq \emptyset$. Since D^3 lies on one side of D^2 (i.e. in \bar{A}) this violates the maximum principle for minimal surfaces.

Having chosen $D_2^n, \dots, D_{M(n)}^n$ as above, we now choose a smooth disk E_1^n bounding γ_1^n and with

$$\mathcal{H}_e^2(E_1^n) \leq \kappa_1^n + \frac{1}{3n}.$$

In fact we cannot apply directly Theorem 8.3 since in this case the curve γ_1^n is not smooth but has, in fact, two corners at the points $(0, 0, \sigma)$ and $(0, 0, -\sigma)$.

γ_1^n lies in one connected component A of $\overline{\mathcal{B}_\sigma^+}$. We now find a new smooth embedded disk D_1^n with

$$\mathcal{H}_e^2(D_1^n) \leq \kappa_1^n + \frac{1}{n}$$

and lying in the interior of A . This suffices to prove (8.10).

Consider the disks D'_1, \dots, D'_l which, among the D_j^n with $j \geq 2$, bound A . We first perturb E_1^n to a smooth embedded F_1^n which intersects all the D'_j . We then inductively modify E_1^n to a new disk which does not intersect D'_j and loses at most $1/(3ln)$ in area. This is done exactly with the procedure outlined above and since the distance between different D'_j 's is always positive, it is clear that while removing the intersections with D'_j we can do it in such a way that we do not add intersections with D'_i for $i < j$.

8.5. Proof of (8.12). In this step we show the existence of a positive δ , independent of n and j , such that

$$\kappa_j^n \leq \sigma \left(\frac{1}{2} - \delta \right) \mathcal{H}_e^1(\gamma_j^n) \quad \forall j \geq 2, \forall n. \quad (8.17)$$

Observe that for each γ_j^n we can construct the cone with vertex the origin, which is topologically a disk and achieves area equal to $\frac{\sigma}{2} \mathcal{H}_e^1(\gamma_j^n)$. On the other hand, this cone is clearly not stationary, because γ_j^n is not a circle, and therefore there is a disk diffeomorphic to the cone with area strictly smaller than $\frac{\sigma}{2} \mathcal{H}_e^1(\gamma_j^n)$. A small perturbation of this disk yields a smooth embedded disk D bounding γ_j^n such that

$$\mathcal{H}_e^2(D) < \frac{\sigma}{2} \mathcal{H}_e^1(\gamma_j^n). \quad (8.18)$$

Therefore, it is clear that it suffices to prove (8.17) when n is large enough.

Next, by the isoperimetric inequality, there is a constant C such that, any curve γ in $\partial\mathcal{B}_\sigma$ bounds, in \mathcal{B}_σ , a disk D such that

$$\mathcal{H}_e^2(D) \leq C (\mathcal{H}_e^1(\gamma))^2. \quad (8.19)$$

Therefore, (8.17) is clear for every γ_j^n with $\mathcal{H}_e^1(\gamma_j^n) \leq \sigma/4C$.

We conclude that the only way of violating (8.17) is to have a subsequence, not relabeled, of curves $\gamma^n := \gamma_{j(n)}^n$ such that

- $\mathcal{H}_e^1(\gamma^n)$ converges to some constant $c_0 > 0$;
- $\kappa^n := \kappa_{j(n)}^n$ converges to $c_0/2$.

Consider next the wedge $\text{Wed} = \{|y_2| \leq y_1 \tan \theta_0\}$ containing the support of the varifold V . If we enlarge this wedge slightly to

$$\text{Wed}' := \{|y_2| \leq y_1(\tan \theta_0 + 1)\},$$

we conclude, by (8.6), that

$$\lim_{n \uparrow \infty} \mathcal{H}_e^1(\gamma^n \setminus \text{Wed}') = 0. \quad (8.20)$$

Perturbing γ^n slightly we find a nearby smooth Jordan curve β^n contained in $\partial\mathcal{B}_\sigma \cap \text{Wed}'$. Consider next

$$\mu^n := \min\{\mathcal{H}_e^2(D) : \text{smooth embedded disk } D \text{ bounding } \beta^n\}. \quad (8.21)$$

Given a D bounding β^n , it is possible to construct a D' bounding γ^n with

$$\mathcal{H}_e^2(D') \leq \mathcal{H}_e^2(D) + o(1).$$

Therefore, we conclude that

- $\mathcal{H}_e^1(\beta^n)$ converges to $c_0 > 0$;
- μ^n converges to $\sigma c_0/2$;
- β^n is contained in Wed' .

Consider next the projection of the curve $\alpha = \text{Wed}' \cap \mathcal{B}_\sigma$ on the plane $\pi = y_1 y_3$. This projection is an ellipse bounding a domain Ω in π . Clearly α is the graph of a function over this ellipse. The function is Lipschitz (actually it is analytic except for the two points $(0, \sigma)$ and $(0, -\sigma)$) and we can therefore find a function $f : \Omega \rightarrow \mathbb{R}$ which minimizes the area of its graph. This function is smooth up to the boundary except in the points $(0, \sigma)$ and $(0, -\sigma)$ where, however, it is continuous. Therefore, the graph of f is an embedded disk.

We denote by Λ the graph of f . Λ is in fact the *unique* area-minimizing current spanning α , by a well-known property of area-minimizing graphs. By the classical maximum principle, Λ is contained in the wedge Wed' and does not contain the origin. Consider next the cone C^n having vertex in 0 and β^n as base. Clearly, this cone intersects Λ in a smooth Jordan curve $\tilde{\beta}^n$ and hence there is a disk D^n in Λ bounding this curve. Moreover, we call E^n the cone constructed on $\tilde{\beta}^n$ with vertex 0 (see Figure 12).

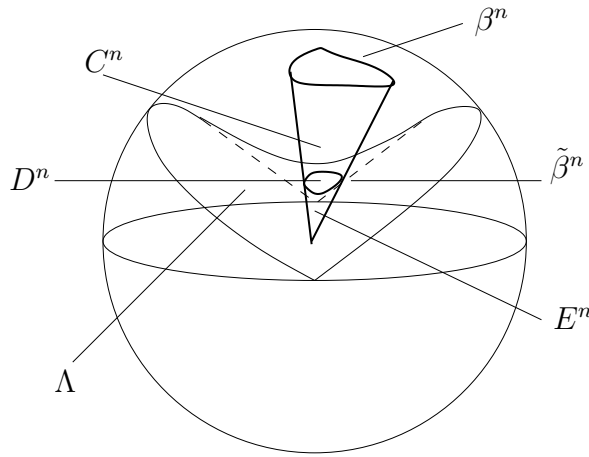

FIGURE 12. The minimal surface Λ , the cones C^n and E^n and the domain D^n .

Clearly,

$$\liminf_{n \uparrow \infty} \mathcal{H}_e^1(\beta^n) > 0. \tag{8.22}$$

Consider next the current given by $D^n \cup (C^n \setminus E^n)$. These converge, up to subsequences, to some integer rectifiable current. Therefore, the disks D^n converge, in the sense of currents, to a 2-dimensional current D supported in Λ . It is easy to check that D must be the current represented by a domain of Λ , counted with multiplicity 1. Therefore

$$\lim_{n \uparrow \infty} \mathcal{H}_e^2(D^n) = \mathcal{H}_e^2(D). \tag{8.23}$$

Similarly, E^n converges, up to subsequences, to a current E . By the minimizing property of Λ , $\mathcal{H}_e^2(D) < \mathbf{M}(E)$, unless $\mathcal{H}_e^2(D) = \mathbf{M}(E) = 0$, where $\mathbf{M}(E)$ denotes the mass of E .

So, if $\mathbf{M}(E) > 0$, we then have

$$\liminf_{n \uparrow \infty} \mathcal{H}_e^2(E^n) \geq \mathbf{M}(E) > \mathcal{H}_e^2(D) = \lim_{n \uparrow \infty} \mathcal{H}_e^2(D^n).$$

If $\mathbf{M}(E) = 0$, by (8.22), we conclude

$$\liminf_{n \uparrow \infty} \mathcal{H}_e^2(E^n) > 0 = \lim_{n \uparrow \infty} \mathcal{H}_e^2(D^n).$$

In both cases we conclude that the embedded disk $H^n = (C^n \setminus E^n) \cup D^n$ bounds β^n and satisfies

$$\lim_{n \uparrow \infty} \mathcal{H}_e^2(H^n) < \lim_{n \uparrow \infty} \mathcal{H}_e^2(C^n) = \frac{\sigma c_0}{2} = \lim_{n \uparrow \infty} \mu^n. \quad (8.24)$$

Therefore, there exists an n such that $\mu^n > \mathcal{H}_e^2(H^n)$. A small perturbation of H^n gives a smooth embedded disk bounding β^n with area strictly smaller than μ^n . This contradicts the minimality of μ^n (see (8.21)) and hence proves our claim.

8.6. Proof of (8.16). In this final step we show (8.16). Our arguments are inspired by those of Section 7 in [4].

Consider the curve γ_1^n . Again applying (8.6) we conclude that, for every compact set

$$K \subset \overline{\mathcal{B}}_\sigma^+ \setminus \bigcup_i P_{\theta_i}$$

we have

$$\lim_{n \uparrow \infty} \mathcal{H}_e^1(\gamma_1^n \setminus K) = 0. \quad (8.25)$$

Consider next the solid sector $S := \text{Wed}' \cap \mathcal{B}_\sigma$. Clearly $\mathcal{H}_e^2(\partial S) = (3\pi - \eta)\sigma^2$, where η is a positive constant. Clearly a curve contained in ∂S bounds always a disk with area at most $\pi(\frac{3}{2} - \frac{\eta}{2})\sigma^2$. For large γ_1^n we can modify it to a new curve $\tilde{\gamma}^n$ contained in ∂S , and hence find a smooth embedded disk bounding $\tilde{\gamma}^n$ with area at most $\pi(\frac{3}{2} - \frac{\eta}{4})\sigma^2$. This and (8.15) implies that

$$\frac{\pi\sigma^2}{2} \sum_i k_i = \lim_{n \uparrow \infty} \kappa_1^n < \frac{3\pi}{2}\sigma^2.$$

Therefore we conclude that $\sum_i k_i \leq 2$.

Extracting a subsequence, not relabeled, we can assume that γ_1^n converges to an integer rectifiable current γ . The intersection of the support of γ with $\partial \mathcal{B}_\sigma \setminus \{(0, 0, \sigma), (0, 0, -\sigma)\}$ is then contained in the arcs $\alpha_i := P_{\theta_i} \cap \partial \mathcal{B}_\sigma$. Therefore if we denote by $[[\alpha_i]]$ the current induced by α_i then we have

$$\gamma \llcorner \partial \mathcal{B}_\sigma = \sum_i h_i [[\alpha_i]]$$

where the h_i are integers.

On the other hand, $\gamma_1^n \llcorner \mathcal{B}_\sigma$ is given by the segment ℓ . Therefore we conclude that

$$\gamma \llcorner \mathcal{B}_\sigma = [[\ell]].$$

It turns out that

$$\gamma = [[\ell]] + \sum_i h_i [[\alpha_i]]$$

and of course $\sum_i |h_i| \leq \sum_i k_i$.

Since $\partial\gamma = 0$, we conclude that

$$0 = \partial[[\ell]] + \sum_i h_i \partial[[\alpha_i]] = \delta_P - \delta_N + \sum_i h_i (\delta_N - \delta_P)$$

where $N = (\sigma, 0, 0)$, $P = (-\sigma, 0, 0)$ and δ_X denotes the Dirac measure in the point X . Hence we conclude

$$\left(1 - \sum_i h_i\right) \delta_P - \left(1 - \sum_i h_i\right) \delta_N = 0$$

and therefore $\sum_i h_i = 1$. This implies that $\sum_i |h_i|$ is odd. Since $\sum_i |h_i| \leq \sum_i k_i \leq 2$, we conclude $\sum_i |h_i| = 1$.

Therefore, γ consists of the segment ℓ and an arc, say, α_1 . Clearly, γ bounds P_{θ_1} , which has area $\pi\sigma^2/2$. Consider next the closed curve β^n made by joining $\gamma_1^n \cap \partial\mathcal{B}_\sigma$ and $-\alpha_1$. These curves might have self-intersections, but they are close. Moreover, they have bounded length and they converge, in the sense of currents, to the trivial current $\alpha_1 - \alpha_1 = 0$.

There are therefore domains $D^n \subset \mathcal{B}_\sigma^+$ such that $\partial D^n = \beta^n$ and $\mathcal{H}_e^2(D^n) \downarrow 0$. It is not difficult to see that the union of the domains D^n and of P_{θ_1} gives embedded disks E^n bounding γ_1^n and with area converging to $\pi\sigma^2/2$ (see Figure 13). Approximating these disks E^n with smooth embedded ones, we conclude that

$$\lim_{n \uparrow \infty} \mu_n \leq \frac{\pi}{2} \sigma^2.$$

This shows that $\sum_i k_i \leq 1$. Hence the varifold W is either trivial or it consists of at most one half-disk. Since it cannot be trivial by the considerations of Subsections 6.1 and 8.1, we conclude that W consists in fact of exactly one half-disk.

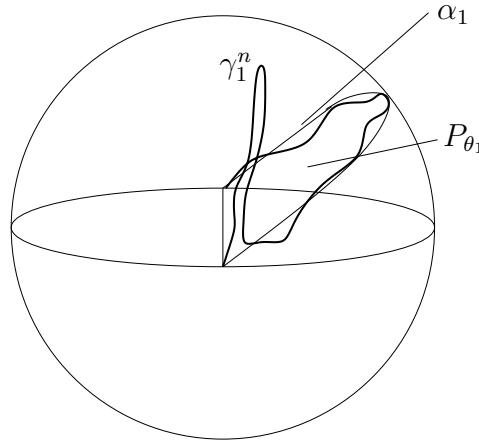

FIGURE 13. The curves γ_1^n and α_1 .

9. PROOF OF PROPOSITION 3.2. PART V: CONVERGENCE OF CONNECTED COMPONENTS

In this section we complete the proofs of Proposition 3.2 and Proposition 3.3. In particular, building on Corollary 8.2, we show the following.

Lemma 9.1. *Let Σ and Δ^k be as in Proposition 3.2 (or as in Proposition 3.3) and consider their varifold limit V . According to Lemma 7.1, Lemma 8.1 and Corollary 8.2, V is a smooth stable minimal surface with boundary $\partial\Delta = \partial\Sigma$ and with multiplicity 1. Let $\Gamma_1, \dots, \Gamma_N$ be the connected components of Δ .*

If $\tilde{\Delta}^k$ is an arbitrary union of connected components of Δ^k which converges, in the sense of varifolds, to a W , then W is given by $\Gamma_{i_1} \cup \dots \cup \Gamma_{i_l}$ for some $1 \leq i_1 < i_2 < \dots < i_l \leq N$.

Proof. This lemma is indeed a simple consequence of some known facts in geometric measure theory. Fix a sequence $\tilde{\Delta}^k$ and a W as in the statement of the lemma. Note that $\partial\tilde{\Delta}^k \subset \partial\Delta^k = \partial\Sigma$.

We can therefore apply the compactness of integer rectifiable currents and, after a further extraction of subsequence, assume that the $\tilde{\Delta}^k$ are converging, as currents, to an integer rectifiable current T with boundary ∂T which is the limit of the boundaries $\partial\tilde{\Delta}^k$. Since these boundaries are all contained in ∂U , we conclude that ∂T is also contained in ∂U . It is a known fact in geometric measure theory that

$$\|T\| \leq \|W\|. \quad (9.1)$$

On the other hand,

$$\|W\| \leq \|V\| \leq \sum_i \mathcal{H}^2 \llcorner \Gamma_i. \quad (9.2)$$

So T is actually supported in the current given by the union of the currents induced by the Γ_i 's, which we denote by $[[\Gamma_i]]$. Since ∂T and $\partial\Gamma_i$ lie both on ∂U , a second standard fact in geometric measure theory imply the existence of integers h_1, \dots, h_N such that

$$T = \sum_{i=1}^N h_i [[\Gamma_i]]$$

Therefore,

$$\|T\| = \sum_i |h_i| \mathcal{H}^2 \llcorner \Gamma_i. \quad (9.3)$$

Hence, (9.1), (9.2) and (9.3) give $h_i \in \{-1, 0, 1\}$. On the other hand, since each $\partial\tilde{\Delta}^k$ is the union of connected components of $\partial\Sigma$ (with positive orientation), it turns out that ∂T is the union of the currents induced by some connected components of $\partial\Sigma$, with *positive* orientation. Moreover, since U is a sufficiently small ball, by the maximum principle each surface Γ_i must have nontrivial boundary. Hence, we conclude that $h_i \in \{0, 1\}$.

Arguing in the same way, we conclude that $\Delta^k \setminus \tilde{\Delta}^k$ converge, as currents, to a current T' , and, as varifolds, to a varifold W' with the properties that

$$T' = \sum_{i=1}^N h'_i [[\Gamma_i]] \quad (9.4)$$

$$\|T'\| \leq \|W'\| \quad (9.5)$$

and $h'_i \in \{0, 1\}$. Since $W + W' = V$, (and hence $\|W\| + \|W'\| = \|V\|$), we conclude that $h''_i = h'_i + h_i \in \{0, 1\}$. On the other hand, Δ^k converges, in the sense of currents, to $T + T'$, which is given by

$$T + T' = \sum_i (h_i + h'_i)[[\Gamma_i]]. \quad (9.6)$$

Moreover, since $\partial\Delta^k = \partial\Sigma$,

$$[[\partial\Sigma]] = \partial(T + T') = \sum_i (h_i + h'_i)[[\partial\Gamma_i]]. \quad (9.7)$$

Since the $\partial\Gamma_i$ are all nonzero, disjoint and contained in $\partial\Sigma$, we conclude that $h_i + h'_i = 1$ for every i .

Summarizing, we conclude that $\|V\| = \|W\| + \|W'\| \geq \|T\| + \|T'\| \geq \|T + T'\| = \|V\|$. This implies that $\|W\| + \|W'\| = \|T\| + \|T'\|$ and hence that $\|W\| = \|T\|$. Therefore

$$\|W\| = \sum_i h_i \mathcal{H}^2 \llcorner \Gamma_i$$

and since $h_i \in \{0, 1\}$, this last claim concludes the proof. \square

10. CONSIDERATIONS ON (0.5) AND (0.4)

10.1. Coverings. In this subsection we discuss why (0.5) seems ultimately the correct estimate. Fix a sequence $\{\Sigma_{t_j}^j\}$ which is $1/j$ -a.m. in sufficiently small annuli and assume for simplicity that each element is a smooth embedded surface and that the varifold limit is given by

$$\Gamma = \sum_{\Gamma^i \in \mathcal{O}} n_i \Gamma^i + \sum_{\Gamma^i \in \mathcal{N}} n_i \Gamma^i.$$

Then, one expects that, after appropriate surgeries (which can only bring the genus down) $\Sigma_{t_j}^j$ split into three groups.

- The first group consists of

$$m_1 = \sum_{\Gamma^i \in \mathcal{O}} n_i$$

surfaces, each isotopic to a $\Gamma^i \in \mathcal{O}$;

- The second group consists of

$$m_2 = \frac{1}{2} \sum_{\Gamma^i \in \mathcal{N}} n_i$$

surfaces, each isotopic to the boundary of a regular tubular neighborhood of $\Gamma^i \in \mathcal{N}$, (which is a double cover of Γ^i);

- The sum of the areas of the the third group vanishes as $j \uparrow \infty$.

As a consequence one would conclude that n_i is even whenever $\Gamma^i \in \mathcal{N}$ and that (0.5) holds.

The type of convergence described above is exactly the one proved by Meeks, Simon and Yau in [13] for sequences of surfaces which are minimizing in a given isotopy class. The key ingredients of their proof is the γ -reduction and the techniques set forth by Almgren and Simon in [4] to discuss sequences of minimizing disks. However, in their situation there is a fundamental advantage: when the sequence $\{\Sigma^j\}$ is minimizing in a given isotopy class, one

can perform the γ -reduction “globally”, and conclude that, after a finite number of surgeries which do not increase the genus, there is a constant $\sigma > 0$ with the following property:

- For any ball B with radius σ , each curve in $\partial B \cap \Sigma^j$ bounds a small disk in Σ^j .

In the case of min-max sequences, their weak $1/j$ -almost minimizing property on subsets of the ambient manifold allows to perform the γ -reduction only to surfaces which are appropriate local modifications of the Σ^j 's, see the Squeezing Lemma of Section 6 and the modified γ -reduction of Section 6. Unfortunately, the size of the open sets where this can be done depends on j . In order to show that the picture above holds, it seems necessary to work directly in open sets of a fixed size.

10.2. An example. In this section we show that (0.4) cannot hold for sequences which are $1/j$ -a.m.. Consider in particular the manifold $M =]-1, 1[\times \mathbf{S}^2$ with the standard product metric. We parameterize \mathbf{S}^2 with $\{|\omega| = 1 : \omega \in \mathbf{R}^3\}$. Consider on M the orientation-preserving diffeomorphism $\varphi : (t, \omega) \mapsto (-t, -\omega)$ and the equivalence relation $x \sim y$ if $x = y$ or $x = \varphi(y)$. Let $N = M/\sim$ be the quotient manifold, which is an oriented Riemannian manifold, and consider the projection $\pi : M \rightarrow N$, which is a local isometry. Clearly, $\Gamma := \pi(\{1\} \times \mathbf{S}^2)$ is an embedded 2-dimensional (real) projective plane. Consider a sequence $t_j \downarrow 1$. Then, each $\Lambda^j := \{t_j\} \times \mathbf{S}^2$ is a totally geodesic surface in M and, therefore, $\Sigma^j = \pi(\Lambda^j)$ is totally geodesic as well. Let r be the injectivity radius of N and consider a smooth open set $U \subset N$ with diameter smaller than r such that ∂U intersects Σ^j transversally. Then $\Sigma^j \cap U$ is the unique area-minimizing surface spanning $\partial U \cap \Sigma^j$.

Hence, the sequence of surfaces $\{\Sigma^j\}$ is $1/j$ -a.m. in sufficiently small annuli of N . Each Σ^j is a smooth embedded minimal sphere and Σ^j converges, in the sense of varifolds, to 2Γ . Since $\mathbf{g}(\Sigma^j) = 0$ and $\mathbf{g}(\Gamma) = 1$, the inequality

$$\mathbf{g}(\Gamma) \leq \liminf_{j \uparrow \infty} \mathbf{g}(\Sigma^j),$$

which corresponds to (0.4), fails in this case.

APPENDIX A. PROOF OF LEMMA 4.2

Proof. Let Σ be a smooth minimal surface with $\partial\Sigma \subset \partial B_\sigma(x)$, where $\sigma < r_0$ and r_0 is a positive constant to be chosen later. We recall that, for every vector field $X \in C_c^1(B_\sigma(x))$, we have

$$\int_{B_\sigma(x)} \operatorname{div}_\Sigma X = 0. \quad (\text{A.1})$$

We assume $r_0 < \operatorname{Inj}(M)$ (the injectivity radius of M) and we use geodesic coordinates centered at x . For every $y \in B_\sigma(x)$ we denote by $r(y)$ the geodesic distance between y and x . Recall that r is Lipschitz on $B_\sigma(x)$ and C^∞ in $B_\sigma(x) \setminus \{x\}$, and that $|\nabla r| = 1$, where $|\nabla r| = \sqrt{g(\nabla r, \nabla r)}$.

We let $\gamma \in C^1([0, 1])$ be a cut-off function, i.e. $\gamma = 0$ in a neighborhood of 1 and $\gamma = 1$ in a neighborhood of 0. We set $X = \gamma(r)r\nabla r = \gamma(r)\nabla \frac{r^2}{2}$. Thus, $X \in C_c^\infty(B_\sigma(x))$ and from (A.1) we compute

$$0 = \int_\Sigma \gamma(r) \operatorname{div}_\Sigma (r\nabla r) + \int_\Sigma r \gamma'(r) \sum_i \partial_{e_i} r g(\nabla r, e_i), \quad (\text{A.2})$$

where $\{e_1, e_2\}$ is an orthonormal frame on $T\Sigma$. Clearly

$$\sum_i \partial_{e_i} r g(\nabla r, e_i) = \sum_i (\partial_{e_i} r)^2 = |\nabla_{\Sigma} r|^2 = |\nabla r|^2 - |\nabla^{\perp} r|^2 = 1 - |\nabla^{\perp} r|^2, \quad (\text{A.3})$$

where $\nabla^{\perp} r$ denotes the projection of ∇r on the normal bundle to Σ . Moreover, let ∇^e be the euclidean connection in the geodesic coordinates and consider a 2-d plane π in $T_y M$, for $y \in B_{\sigma}(x)$. Then

$$\operatorname{div}_{\pi}(r(y) \nabla r(y)) - \operatorname{div}_{\pi}^e(|y| \nabla^e |y|) = O(|y|) = O(\sigma).$$

Since $\operatorname{div}_{\pi}^e(|y| \nabla^e |y|) = 2$, we conclude the existence of a constant C such that

$$\left| \int_{\Sigma} \gamma(r) \operatorname{div}_{\Sigma}(r \nabla r) - 2 \int_{\Sigma} \gamma(r) \right| \leq C \|\gamma\|_{\infty} \sigma \mathcal{H}^2(\Sigma \cap B_{\sigma}(x)). \quad (\text{A.4})$$

Inserting (A.3) and (A.4) in (A.2), we conclude

$$\int_{\Sigma} 2\gamma(r) + \int_{\Sigma} r \gamma'(r) = \int_{\Sigma} r \gamma'(r) |\nabla^{\perp} r|^2 + \operatorname{Err} \quad (\text{A.5})$$

where, if we test with functions γ taking values in $[0, 1]$, we have

$$|\operatorname{Err}| \leq C \sigma \mathcal{H}^2(\Sigma \cap B_{\sigma}(x)). \quad (\text{A.6})$$

We test now (A.5) with functions taking values in $[0, 1]$ and approximating the characteristic functions of the interval $[0, \sigma]$. Following the computations of pages 83-84 of [18], we conclude

$$\frac{d}{d\rho} (\rho^{-2} \mathcal{H}^2(\Sigma \cap B_{\rho}(x))) \Big|_{\rho=\sigma} = \frac{d}{d\rho} \left(\int_{\Sigma \cap B_{\rho}(x)} \frac{|\nabla^{\perp} r|^2}{r^2} \right) \Big|_{\rho=\sigma} + \sigma^{-3} \operatorname{Err}. \quad (\text{A.7})$$

Straightforward computations lead to

$$\mathcal{H}^2(\Sigma \cap B_{\sigma}(x)) = \underbrace{\frac{\sigma}{2} \frac{d}{d\rho} (\mathcal{H}^2(\Sigma \cap B_{\rho}(x))) \Big|_{\rho=\sigma} - \frac{\sigma^3}{2} \frac{d}{d\rho} \left(\int_{\Sigma \cap B_{\rho}(x)} \frac{|\nabla^{\perp} r|^2}{r^2} \right) \Big|_{\rho=\sigma}}_{=(A)} + \operatorname{Err}. \quad (\text{A.8})$$

Moreover, by the coarea formula, we have

$$\begin{aligned} (A) &= \frac{\sigma}{2} \int_{\partial B_{\sigma}(x) \cap \Sigma} \frac{1}{|\nabla_{\Sigma} r|} - \frac{\sigma^3}{2} \int_{\partial B_{\sigma}(x) \cap \Sigma} \frac{|\nabla^{\perp} r|^2}{\sigma^2 |\nabla_{\Sigma} r|} = \frac{\sigma}{2} \int_{\partial \Sigma} \frac{1 - |\nabla^{\perp} r|^2}{|\nabla_{\Sigma} r|} \\ &= \frac{\sigma}{2} \int_{\partial \Sigma} |\nabla_{\Sigma} r| \leq \frac{\sigma}{2} \operatorname{Length}(\partial \Sigma). \end{aligned} \quad (\text{A.9})$$

Inserting (A.9) into (A.8), we conclude that

$$\mathcal{H}^2(\Sigma \cap B_{\sigma}(x)) \leq \frac{\sigma}{2} \operatorname{Length}(\partial \Sigma) + |\operatorname{Err}|, \quad (\text{A.10})$$

which, taking into account (A.6), becomes

$$(1 - C\sigma) \mathcal{H}^2(\Sigma \cap B_{\sigma}(x)) \leq \frac{\sigma}{2} \operatorname{Length}(\partial \Sigma). \quad (\text{A.11})$$

So, for $r_0 < \min\{\operatorname{Inj}(M), (2C)^{-1}\}$ we get (4.16). \square

APPENDIX B. PROOF OF LEMMA 5.5

Proof. Let $d_e(y)$ be the euclidean distance of y to \overline{U} and $d(y)$ the geodesic distance of y to $\overline{f(U)}$. The function d_e is C^2 and uniformly convex on the closure of $\mathcal{B}_1 \setminus U$. Therefore, if ε_0 is sufficiently small, the function d is uniformly convex on the closure of $B_\varepsilon(x) \setminus f(U)$. Let now $y_0 \in B_\varepsilon(x) \setminus \overline{f(U)}$. In order to find $\pi(x)$ it suffices to follow the flow line of the ODE $\dot{y} = -\nabla d(y)/|\nabla d(y)|^2$, with initial condition $y(0) = y_0$, until the line hits $\overline{f(U)}$. Thus, the inequality $|\nabla \pi(x)| < 1$ follows from Lemma 1 of [7]. On the other hand, $\pi(x) = x$ on $\overline{f(U)}$, and therefore the map is Lipschitz with constant 1. \square

APPENDIX C. A SIMPLE TOPOLOGICAL FACT

We summarize the topological fact used in (a) of Section 8.3 in the following lemma.

Lemma C.1. *Consider a smooth 2-dimensional surface $\Sigma \subset \mathcal{B}_1$ with smooth boundary $\partial\Sigma \subset \partial\mathcal{B}_1$. Let $\Gamma \subset \mathcal{B}_1$ is a smooth surface with $\partial\Gamma = \partial\Sigma$ consisting of disjoint embedded disks. Then there exists a smooth map $\Phi : [0, 1[\times \overline{\mathcal{B}_1} \rightarrow \overline{\mathcal{B}_1}$ such that*

- (i) $\Phi(0, \cdot)$ is the identity and $\Phi(t, \cdot)$ is a diffeomorphism for every t ;
- (ii) For every t there exists a neighborhood U_t of $\partial\mathcal{B}_1$ such that $\Phi(t, x) = x$ for every $x \in U_t$;
- (iii) $\Phi(t, \Sigma)$ converges to Γ in the sense of varifolds as $t \rightarrow 1$.

Proof. The proof consists of two steps. In the first one we show the existence of a surface Γ' and of a map $\Psi : [0, 1[\times \overline{\mathcal{B}_1} \rightarrow \overline{\mathcal{B}_1}$ such that

- $\partial\Gamma' = \partial\Sigma$,
- Γ' consists of disjoint embedded disks,
- Ψ satisfies (i) and (ii),
- $\Psi(t, \Sigma) \rightarrow \Gamma'$ as $t \rightarrow 1$.

In the second we show the existence of a $\tilde{\Psi} : [0, 1[\times \overline{\mathcal{B}_1} \rightarrow \overline{\mathcal{B}_1}$ such that (i) and (ii) hold and $\tilde{\Psi}(t, \Gamma') \rightarrow \Gamma$ as $t \rightarrow 1$.

In order to complete the proof from these two steps, consider the map $\tilde{\Phi}(s, t, x) = \tilde{\Psi}(t, \Psi(s, x))$. Then, for every smooth $g : [0, 1[\rightarrow [0, 1[$ with $g(0) = 0$, the map $\Phi(t, x) = \tilde{\Phi}(g(t), t, x)$ satisfies (i) and (ii) of the Lemma. Next, for any fixed t , if s is sufficiently close to 1, then $\tilde{\Phi}(s, t, \Sigma)$ is close, in the sense of varifolds, to $\tilde{\Psi}(t, \Gamma')$. This allows to find a piecewise constant function $h : [0, 1[\rightarrow [0, 1[$ such that

$$\lim_{t \rightarrow 1} \tilde{\Phi}(g(t), t, \Sigma) = \Gamma \quad (\text{in the sense of varifolds})$$

whenever $g \geq h$ in a neighborhood of 1. If we choose, therefore, a smooth $g : [0, 1[\rightarrow [0, 1[$ with $g(0) = 0$ and $g \geq h$ on $[1/2, 1[$, the map $\Phi(t, x) = \tilde{\Phi}(g(t), t, x)$ satisfies all the requirements of the lemma.

We now come to the existence of the maps Ψ and $\tilde{\Psi}$.

Existence of Ψ . Let \mathcal{G} be the set of all surfaces Γ' which can be obtained as $\lim_{t \rightarrow 1} \Psi(t, \Sigma)$ for maps Ψ satisfying (i) and (ii). It is easy to see that any Γ' which is obtained from Σ through surgery as in Definition 2.2 is contained in \mathcal{G} . Let \mathbf{g}_0 be the smallest genus of a surface contained in \mathcal{G} . It is then a standard fact that $\mathbf{g}(\Gamma') = \mathbf{g}_0$ if and only if the surface is incompressible. However, if this holds, then the first homotopy group of Γ' is mapped

injectively in the homotopy group of \mathcal{B}_1 (see for instance [11]). Therefore there is a $\Gamma' \in \mathcal{G}$ which consists of disjoint embedded disks and spheres. The embedded spheres can be further removed, yielding a $\Gamma' \in \mathcal{G}$ consisting only of disjoint embedded disks.

Existence of $\tilde{\Psi}$. Note that each connected component of $\mathcal{B}_1 \setminus \Gamma'$ (and of $\mathcal{B}_1 \setminus \Gamma$) is a, piecewise smooth, embedded sphere. Therefore the claim can be easily proved by induction from the case in which Γ and Γ' consist both of a single embedded disk. This is, however, a standard fact (see once again [11]). \square

Acknowledgments Both authors have been supported by a grant of the Swiss National Foundation.

REFERENCES

- [1] W. K. Allard and F. J. Almgren, Jr. The structure of stationary one dimensional varifolds with positive density. *Invent. Math.*, 34(2):83–97, 1976.
- [2] William K. Allard. On the first variation of a varifold. *Ann. of Math. (2)*, 95:417–491, 1972.
- [3] William K. Allard. On the first variation of a varifold: boundary behavior. *Ann. of Math. (2)*, 101:418–446, 1975.
- [4] Frederick J. Almgren, Jr. and Leon Simon. Existence of embedded solutions of Plateau’s problem. *Ann. Scuola Norm. Sup. Pisa Cl. Sci. (4)*, 6(3):447–495, 1979.
- [5] Frederick J. Almgren Jr. The theory of varifolds. Mimeographed notes, Princeton University, 1965.
- [6] Luigi Ambrosio, Nicola Fusco, and Diego Pallara. *Functions of bounded variation and free discontinuity problems*. Oxford Mathematical Monographs. The Clarendon Press Oxford University Press, New York, 2000.
- [7] Victor Bangert. Riemannsche Mannigfaltigkeiten mit nicht-konstanter konvexer Funktion. *Arch. Math. (Basel)*, 31(2):163–170, 1978/79.
- [8] Tobias H. Colding and Camillo De Lellis. The min-max construction of minimal surfaces. In *Surveys in differential geometry, Vol. VIII (Boston, MA, 2002)*, Surv. Differ. Geom., VIII, pages 75–107. Int. Press, Somerville, MA, 2003.
- [9] Charles Frohman and Joel Hass. Unstable minimal surfaces and Heegaard splittings. *Invent. Math.*, 95(3):529–540, 1989.
- [10] M. Grüter and J. Jost. On embedded minimal disks in convex bodies. *Ann. Inst. H. Poincaré Anal. Non Linéaire*, 3(5):345–390, 1986.
- [11] William Jaco. *Lectures on three-manifold topology*, volume 43 of *CBMS Regional Conference Series in Mathematics*. American Mathematical Society, Providence, R.I., 1980.
- [12] William S. Massey. *A basic course in algebraic topology*, volume 127 of *Graduate Texts in Mathematics*. Springer-Verlag, New York, 1991.
- [13] William Meeks, III, Leon Simon, and Shing Tung Yau. Embedded minimal surfaces, exotic spheres, and manifolds with positive Ricci curvature. *Ann. of Math. (2)*, 116(3):621–659, 1982.
- [14] Jon T. Pitts. *Existence and regularity of minimal surfaces on Riemannian manifolds*, volume 27 of *Mathematical Notes*. Princeton University Press, Princeton, N.J., 1981.
- [15] Jon T. Pitts and J. H. Rubinstein. Existence of minimal surfaces of bounded topological type in three-manifolds. In *Miniconference on geometry and partial differential equations (Canberra, 1985)*, volume 10 of *Proc. Centre Math. Anal. Austral. Nat. Univ.*, pages 163–176. Austral. Nat. Univ., Canberra, 1986.
- [16] Jon T. Pitts and J. H. Rubinstein. Applications of minimax to minimal surfaces and the topology of 3-manifolds. In *Miniconference on geometry and partial differential equations, 2 (Canberra, 1986)*, volume 12 of *Proc. Centre Math. Anal. Austral. Nat. Univ.*, pages 137–170. Austral. Nat. Univ., Canberra, 1987.
- [17] Richard Schoen. Estimates for stable minimal surfaces in three-dimensional manifolds. In *Seminar on minimal submanifolds*, volume 103 of *Ann. of Math. Stud.*, pages 111–126. Princeton Univ. Press, Princeton, NJ, 1983.

- [18] Leon Simon. *Lectures on geometric measure theory*, volume 3 of *Proceedings of the Centre for Mathematical Analysis, Australian National University*. Australian National University Centre for Mathematical Analysis, Canberra, 1983.
- [19] F. Smith. On the existence of embedded minimal 2-spheres in the 3-sphere, endowed with an arbitrary riemannian metric. Phd thesis, Supervisor: Leon Simon, University of Melbourne, 1982.

INSTITUT FÜR MATHEMATIK, UNIVERSITÄT ZÜRICH, CH-8057 ZÜRICH

E-mail address: `camillo.delellis@math.uzh.ch` and `filippo.pellandini@math.uzh.ch`